

STUDY MATERIAL ON
MECHANICAL OPERATION IN MINES

(TH-4) 3RD. SEMESTER



Prepared by

SUSHANTA KUMAR MOHANTA, LECTURER

DEPARTMENT OF MECHANICAL ENGINEERING

GOVT. POLYTECHNIC JAJPUR

CHAPTER 1

STRENGTH OF MATERIALS AND POWER TRANSMISSION

Strength of material is defined as the study of ability of material to resist its failure and behaviours under the action of external force.

It has observed that under the action of external force the material first deformed and then its fracture takes place. A detailed study of force and their effects along with some suitable protective measures for safe working is known as SOM.

ELASTICITY

The property of material of returning back to its original shape and size after returning the external force is known as elasticity.

This property occurs within some limit and this limit is known as elastic limit.

If it returns back completely to its original shape and size the body is known as perfect elastic body. If it doesn't returns back completely to its original shape and size is known as partial elastic body.

STRESS:-

The resistance force offers to deformation per unit area is known as stress.

It is denoted by σ .

Let, $P =$ Force/ Load acting on the body.

$A =$ Cross-sectional area of the body.

Then, stress, $\sigma = F/A$

Unit:

S.I unit – $N/m^2 = 1$ Pascal.

$1\text{MPa} = 1\text{N/mm}^2$

$1\text{GPa} = 1\text{KN/mm}^2$

STRAIN

It is defined as the ratio between change in dimensions to the original dimension.

It is denoted by – ϵ

$$\epsilon = \frac{\delta l}{l}$$

Where, $\delta l =$ Change in length and

$l =$ Original length

It has no unit it is a pure number.

TYPES OF STRESS

1. Tensile stress.

2. Compressive stress.

1. Tensile stress:-

When a body is subjected to two equal and opposite pulls and the body tends to increase its length, the stress induced is called tensile stress. The corresponding strain is called tensile strain. As a result of the tensile stress, the cross-sectional area of the body gets reduced.



Tensile stress

Compressive stress

Compressive stress:

When a body is subjected to two equal and opposite pushes and the body tends to shorten its length, the stress induced is called compressive stress. The corresponding strain is called compressive strain. As a result of the compressive stress, the cross-sectional area of the body gets increased.

ELASTIC LIMIT :-

For a given body there is a limiting value of force up to and within which, the deformation entirely disappears on the removal of external force. The value of stress corresponding to this limiting force is called elastic limit of the material.

HOOK'S LAW :-

This law states that, When a material is loaded, within elastic limit, the stress is proportional to the strain.

Mathematically,

$$\frac{\text{Stress}}{\text{Strain}} = E = \text{Constant}$$

LIMIT OF PROPORTIONALITY

The limit of proportionality is the point within which stress is proportional to strain beyond which they are not proportion.

MODULUS OF ELASTICITY OR YOUNG'S MODULUS (E) :-

From Hooks law we that,

$$\begin{aligned}\sigma &\propto \epsilon \\ &= E \times \epsilon\end{aligned}$$

Or

$$E = \frac{\sigma}{\epsilon}$$

σ = Stress,

ϵ = Strain, and

E = A constant of proportionality known as modulus of elasticity or Young's modulus.

FACTOR OF SAFETY:-

It is defined as the ratio between maximum stress to working or design stress.

$$\text{F.O.S} = \frac{\text{Maximum stress}}{\text{Working or design stress}}$$

LATERAL STRAIN:-

The change in lateral dimension to the original lateral dimension is known as lateral strain

POISSON'S RATIO:-

It is the ratio between lateral strain to longitudinal strain.

STRESS - STRAIN CURVE FOR DUCTILE MATERIAL:-

Suppose that a metal specimen be placed in tension-compression-testing machine. As the axial load is gradually increased in increments, the total elongation over the gauge length is measured at each increment of the load and this is continued until failure of the specimen takes place. Knowing the original cross-sectional area and length of the specimen, the normal stress σ and the strain ϵ can be obtained. The graph of these quantities with the stress σ along the y-axis and the strain ϵ along the x-axis is called the stress-strain diagram. The diagram shown below is that for a medium-carbon structural steel (Mild steel).

Point A:

The elastic limit is the limit beyond which the material will no longer go back to its original shape when the load is removed, or it is the maximum stress that may be developed such that there is no permanent or residual deformation when the load is entirely removed.

Point B:

It represents upper yield point of the material. It is the point where material starts yielding or elongation. After this point the curve is no longer a straight line. After this point, the material undergoes more rapid deformation. This point gives the yields strength of the material. Yield stress is defined as the stress after which material extension takes place more quickly with no or little increase in load.

Point C:

It represents the lower yield point of the material. It is point after which material try to regain its strength.

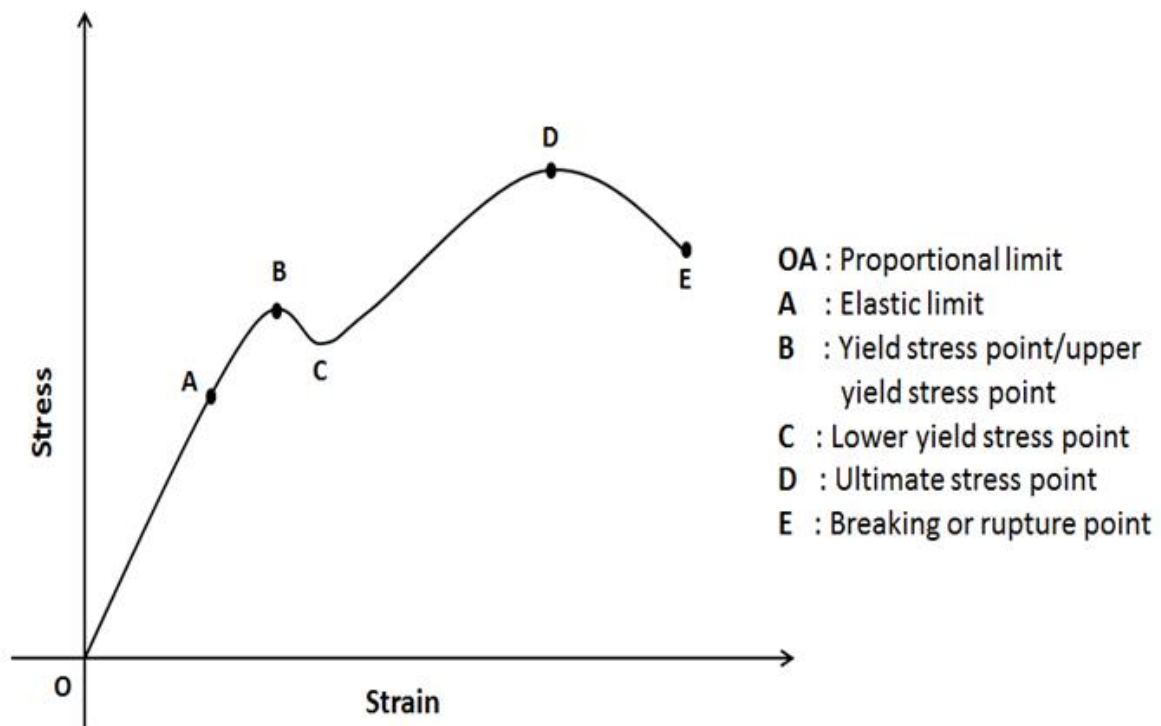

The various important points achieved in this curve are discussed below:

Point D:

It represents the ultimate strength of the material. It is the maximum stress value that material can withstand. It is the point of interest for design engineers. This ultimate strength is referred as the tensile strength of material.

Point E:

It represents breaking point. It is the point occurred after maximum deformation. The stress associates with this point known as breaking strength or rupture strength.

Deformation of a body due to force acting on it:-

Consider a body subjected to a tensile stress.

- Let P = Load or force acting on the body,
- l = Length of the body,
- A = Cross-sectional area of the body,
- σ = Stress induced in the body,
- E = Modulus of elasticity for the material of the body,
- ϵ = Strain, and
- δl = Deformation of the body.

We know that the stress

$$\sigma = \frac{P}{A}$$

and, Strain, $\epsilon = \frac{\sigma}{E} = \frac{P}{AE}$

And deformation, $\delta l = \epsilon \cdot l = \frac{\sigma \cdot l}{E} = \frac{Pl}{AE}$

PROBLEM

A steel rod 1 m long and 20 mm × 20 mm in cross-section is subjected to a tensile force of 40 kN. Determine the elongation of the rod, if modulus of elasticity for the rod material is 200 GPa.

SOLUTION . Given data :

Length (l) = 1 m = 1 × 10³ mm

Cross-sectional area (A) = 20 × 20 = 400 mm²

Tensile force (P) = 40 kN = 40 × 10³ N and

modulus of elasticity (E) = 200 GPa = 200 × 10³ N/mm² .

We know that elongation of the rod,

$$\delta l = \frac{Pl}{AE} = \frac{(40 \times 10^3) \times (1 \times 10^3)}{400 \times (20 \times 10^3)} = 0.5 \text{ mm}$$

PROBLEM:-

A hollow cylinder 2 m long has an outside diameter of 50 mm and inside diameter of 30 mm. If the cylinder is carrying a load of 25 kN, find the stress in the cylinder. Also find the deformation of the cylinder, if the value of modulus of elasticity for the cylinder material is 100 GPa.

SOLUTION . Given data:

Length (l) = 2 m = 2 × 10³ mm

Outside diameter (D) = 50 mm

Inside diameter (d) = 30 mm

Load (P) = 25 kN = 25 × 10³ N and

modulus of elasticity (E) = 100 GPa = 100 × 10³ N/mm² .

Stress in the cylinder

We know that cross-sectional area of the hollow cylinder.

$$A = \frac{\pi}{4} \times (D^2 - d^2) = \frac{\pi}{4} \times [(50)^2 - (30)^2] = 1257 \text{ mm}^2$$

And stress in the cylinder, $\sigma = \frac{P}{A} = \frac{25 \times 10^3}{1257} = 19.9 \text{ N/mm}^2 = 19.9 \text{ MPa}$.

Deformation of the cylinder

We know that the deformation of the cylinder,

$$\delta l = \frac{Pl}{AE} = \frac{(25 \times 10^3) \times (2 \times 10^3)}{1257 \times (100 \times 10^3)} = 0.4 \text{ mm}$$

PROBLEM:-

A load of 5 kN is to be raised with the help of a steel wire. Find the minimum diameter of the steel wire, if the stress is not to exceed 100 MPa.

SOLUTION . Given data:

Load (P) = 5 kN = 5×10^3 N and

stress (σ) = 100 MPa = 100 N/mm²

Let d = Diameter of the wire in mm.

We know that stress in the steel wire (σ),

$$\sigma = 100 = \frac{P}{A} = \frac{5 \times 10^3}{\frac{\pi}{4} \times (d)^2} = \frac{6.366 \times 10^3}{d^2}$$

$$\Rightarrow d^2 = \frac{6.366 \times 10^3}{100}$$

$$\Rightarrow d = 7.98 \text{ mm}$$

PROBLEM:-

In an experiment, a steel specimen of 13 mm diameter was found to elongate 0.2 mm in a 200 mm gauge length when it was subjected to a tensile force of 26.8 kN. If the specimen was tested within the elastic range, what is the value of Young's modulus for the steel specimen?

PROBLEM:-

A hollow steel tube 3.5 m long has external diameter of 120 mm. In order to determine the internal diameter, the tube was subjected to a tensile load of 400 kN and extension was measured to be 2 mm. If the modulus of elasticity for the tube material is 200 GPa, determine the internal diameter of the tube.

PROBLEM:-

Two wires, one of steel and the other of copper, are of the same length and are subjected to the same tension. If the diameter of the copper wire is 2 mm, find the diameter of the steel wire, if they are elongated by the same amount. Take E for steel as 200 GPa and that for copper as 100 GPa.

Deformation of a Body Due to Self Weight

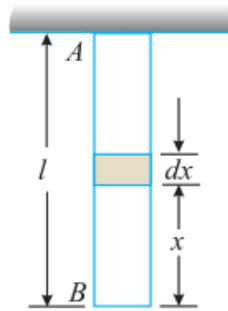

Consider a bar AB hanging freely under its own weight as shown in Fig.

Let l = Length of the bar.

A = Cross-sectional area of the bar.

E = Young's modulus for the bar material,

and w = Specific weight of the bar material.

Now consider a small section dx of the bar at a distance x from B. We know that weight of the bar for a length of x ,

$$P = wAx$$

\therefore Elongation of the small section of the bar, due to weight of the bar for a small section of length x ,

$$= \frac{Pl}{AE} = \frac{(wAx) \cdot dx}{AE} = \frac{wx \cdot dx}{E}$$

Total elongation of the bar may be found out by integrating the above equation between zero and l . Therefore total elongation,

$$\begin{aligned} \delta l &= \int_0^l \frac{wx \cdot dx}{E} \\ &= \frac{w}{E} \int_0^l x \cdot dx \\ &= \frac{w}{E} \left[\frac{x^2}{2} \right]_0^l \end{aligned}$$

$$\text{or} \quad \delta l = \frac{wl^2}{2E} = \frac{Wl}{2AE} \quad (W = wAl = \text{total weight})$$

PROBLEM:-

A copper alloy wire of 1.5 mm diameter and 30 m long is hanging freely from a tower. What will be its elongation due to self weight? Take specific weight of the copper and its modulus of elasticity as 89.2 kN/m³ and 90 GPa respectively.

SOLUTION . Given data:

Diameter (d) = 1.5 mm

Length (l) = 30 m = 30×10^3 mm

Specific weight (w) = $89.2 \text{ kN/m}^3 = 89.2 \times 10^{-9} \text{ kN/mm}^3 = 89.2 \times 10^{-6} \text{ N/mm}^3$
and modulus of elasticity (E) = $90 \text{ GPa} = 90 \times 10^3 \text{ N/mm}^2$.

We know that elongation of the wire due to self weight,

$$\delta l = \frac{wl^2}{2E} = \frac{(89.2 \times 10^{-6}) \times (30 \times 10^3)^2}{2 \times (90 \times 10^3)} = 0.45 \text{ mm}$$

PROBLEM:-

An alloy wire of 2 mm^2 cross-sectional area and 12 N weight hangs freely under its own weight. Find the maximum length of the wire, if its extension is not to exceed 0.6 mm. Take E for the wire material as 150 GPa.

SOLUTION . Given data:

Cross-sectional area (A) = 2 mm^2

Weight (W) = 12 N

Extension (δl) = 0.6 mm

and modulus of elasticity (E) = $150 \text{ GPa} = 150 \times 10^3 \text{ N/mm}^2$.

Let l = Maximum length of the wire,

We know that extension of the wire under its own weight,

$$0.6 = \frac{Wl}{2AE} = \frac{12 \times l}{2 \times 2 \times (150 \times 10^3)} = 0.02 \times 10^{-3} \times l$$

$$\therefore l = \frac{0.6}{0.02 \times 10^{-3}} = 30000 \text{ mm} = 30 \text{ m}.$$

PROBLEM:-

A steel wire ABC 16 m long having cross-sectional area of 4 mm^2 weighs 20 N as shown in figure. If the modulus of elasticity for the wire material is 200 GPa, find the deflections at C and B.

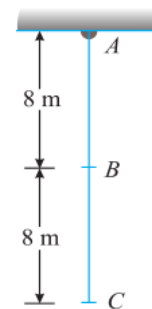

SOLUTION . Given data:

Length (l) = 16 m = 16×10^3 mm

Cross-sectional area (A) = 4 mm^2

Weight of the wire ABC (W) = 20 N

and modulus of elasticity (E) = 200 GPa = 200×10^3 N/mm².

Deflection at C

We know that deflection of wire at C due to self weight of the wire AC,

$$\delta l_C = \frac{W l}{2 A E} = \frac{20 \times (16 \times 10^3)}{2 \times 4 \times (200 \times 10^3)} = 0.2 \text{ mm}$$

Deflection at B

We know that the deflection at B consists of deflection of wire AB due to self weight plus deflection due to weight of the wire BC. We also know that deflection of the wire at B due to self weight of wire AB

$$\delta l_1 = \frac{(W/2) \times (l/2)}{2 A E} = \frac{10 \times (8 \times 10^3)}{2 \times 4 \times (200 \times 10^3)} = 0.05 \text{ mm}$$

and deflection of the wire at B due to weight of the wire BC.

$$\delta l_2 = \frac{(W/2) \times (l/2)}{A E} = \frac{10 \times (8 \times 10^3)}{4 \times (200 \times 10^3)} = 0.01 \text{ mm}$$

∴ Total deflection of the wire at B.

$$\delta l_B = \delta l_1 + \delta l_2 = 0.05 + 0.1 = 0.15 \text{ mm}$$

Principle of Superposition

Sometimes, a body is subjected to a number of forces acting on its outer edges as well as at some other sections, along the length of the body. In such a case, the forces are split up and their effects are considered on individual sections. The resulting deformation, of the body, is equal to the algebraic sum of the deformations of the individual sections. Such a principle, of finding out the resultant deformation, is called the principle of superposition.

The relation for the resulting deformation may be modified as:

$$\delta l = \frac{P l}{A E} = \frac{1}{A E} (P_1 l_1 + P_2 l_2 + P_3 l_3 + \dots)$$

where P_1 = Force acting on section 1,

l_1 = Length of section 1,

P_2, l_2 = Corresponding values of section 2, and so on.

PROBLEM:-

A steel bar of cross-sectional area 200 mm² is loaded as shown in Fig. Find the change in length of the bar. Take E as 200 GPa.

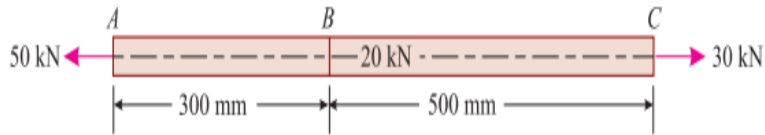

SOLUTION.

Given data:

Cross-sectional area (A) = 200 mm² and

modulus of elasticity (E) = 200 GPa = 200 × 10³ N/mm² .

For the sake of simplification, the force of 50 kN acting at A may be split up into two forces of 20 kN and 30 kN respectively.

Now it will be seen that part AB of the bar is subjected to a tension of 20 kN and AC is subjected to a tension of 30 kN as shown in Fig.

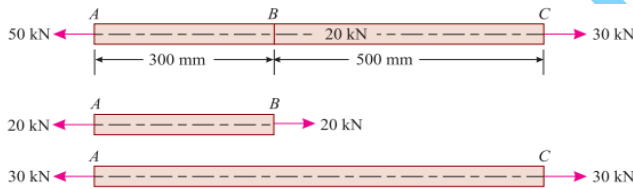

We know that change in length of the bar.

$$\begin{aligned} \delta l &= \frac{P l}{A E} = \frac{1}{A E} (P_1 l_1 + P_2 l_2) \\ &= \frac{1}{200 \times 200 \times 10^3} [[(20 \times 10^3) \times (300)] + [(30 \times 10^3) \times (800)]] \\ &= 0.75 \text{ mm} \end{aligned}$$

PROBLEM:-

A brass bar, having cross-sectional area of 500 mm² is subjected to axial forces as shown in Fig.

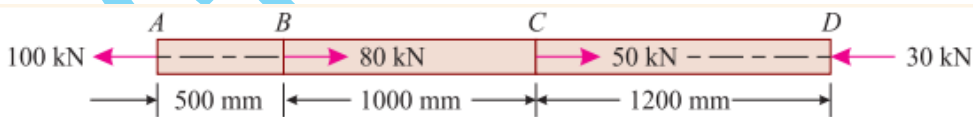

Find the total elongation of the bar. Take E = 80 GPa.

SOLUTION

Given data:-

Cross-sectional area (A) = 500 mm²

and modulus of elasticity (E) = 80 GPa = 80 kN/mm² .

For the sake of simplification, the force of 100 kN acting at A may be split up into two forces of 80 kN and 20 kN respectively. Similarly, the force of 50 kN acting at C may also be split up into two forces of 20 kN and 30 kN respectively.

Now it will be seen that the part AB of the bar is subjected to a tensile force of 80 kN, part AC is subjected to a tensile force of 20 kN and the part CD is subjected to a compression force of 30 kN as shown in figure.

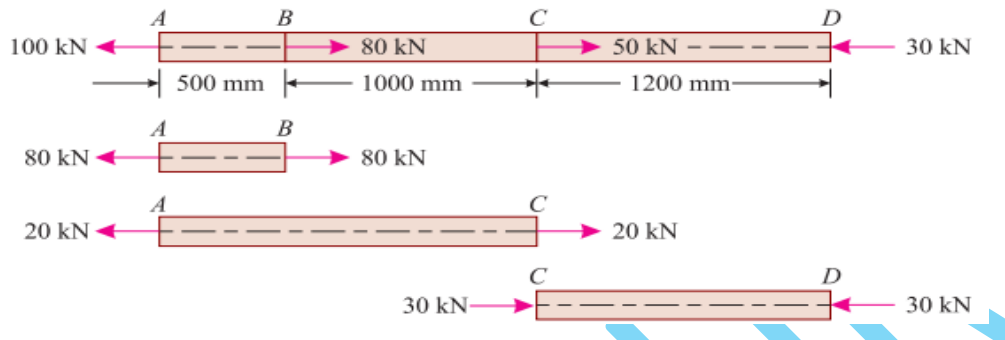

We know that elongation for the bar,

$$\delta l = \frac{1}{AE} (P_1 l_1 + P_2 l_2 + P_3 l_3)$$

$$= \frac{1}{500 \times 80 \times 10^3} [[(80 \times 10^3) \times (500)] + [(20 \times 10^3) \times (1500)] - [(30 \times 10^3) \times (1200)]]$$

$$= 0.85 \text{ mm}$$

PROBLEM:-

A steel rod ABCD 4.5 m long and 25 mm in diameter is subjected to the forces as shown in Fig. If the value of Young's modulus for the steel is 200 GPa, determine its deformation.

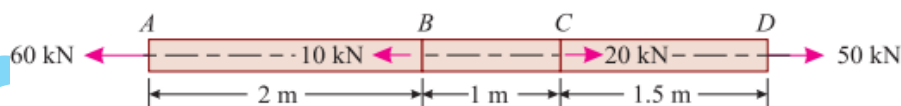

Stresses in the Bars of Different Sections

Sometimes a bar is made up of different lengths having different cross-sectional areas as shown in figure.

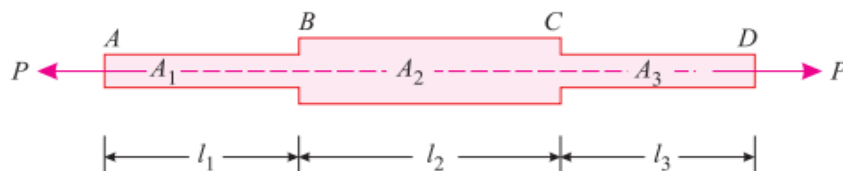

In such cases, the stresses, strains and hence changes in lengths for each section is worked out separately as usual. The total changes in length is equal to the sum of the changes of all the individual lengths. It may be noted that each section is subjected to the same external axial pull or push.

Let P = Force acting on the body,

E = Modulus of elasticity for the body,

l_1 = Length of section 1,

A_1 = Cross-sectional area of section 1,

l_2, A_2 = Corresponding values for section 2 and so on.

We know that the change in length of section 1.

$$\delta l_1 = \frac{P l_1}{A_1 E} \quad \text{Similarly } \delta l_2 = \frac{P l_2}{A_2 E} \quad \text{and so on.}$$

∴ Total deformation of the bar,

$$\begin{aligned} \delta l &= \delta l_1 + \delta l_2 + \delta l_3 + \dots \\ &= \frac{P l_1}{A_1 E} + \frac{P l_2}{A_2 E} + \frac{P l_3}{A_3 E} + \dots \\ &= \frac{P}{E} \left(\frac{l_1}{A_1} + \frac{l_2}{A_2} + \frac{l_3}{A_3} + \dots \right) \end{aligned}$$

Sometimes, the modulus of elasticity is different for different sections. In such cases, the total deformation,

$$\delta l = P \left(\frac{l_1}{A_1 E_1} + \frac{l_2}{A_2 E_2} + \frac{l_3}{A_3 E_3} + \dots \right)$$

PROBLEM

An automobile component shown in Fig. is subjected to a tensile load of 160 kN.

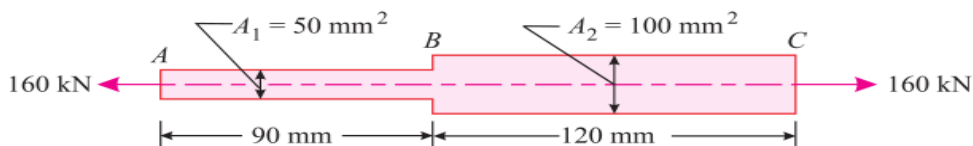

Determine the total elongation of the component, if its modulus of elasticity is 200 GPa.

SOLUTION:-

Given data:

Tensile load (P) = 160 kN = 160×10^3 N,

Length of section 1 (l_1) = 90 mm;

Length of section 2 (l_2) = 120 mm,

Area of section 1 (A_1) = 50 mm^2 ,

Area of section 2 (A_2) = 100 mm^2

and modulus of elasticity (E) = 200 GPa = $200 \times 10^3 \text{ N/mm}^2$.

We know that total elongation of the component,

$$\begin{aligned}\delta l &= \frac{P}{E} \left(\frac{l_1}{A_1} + \frac{l_2}{A_2} \right) = \frac{160 \times 10^3}{200 \times 10^3} \left(\frac{90}{50} + \frac{120}{100} \right) \\ &= 0.8 \times 1.8 + 1.2 \\ &= 2.4 \text{ mm}\end{aligned}$$

PROBLEM

A member formed by connecting a steel bar to an aluminium bar is shown in fig.

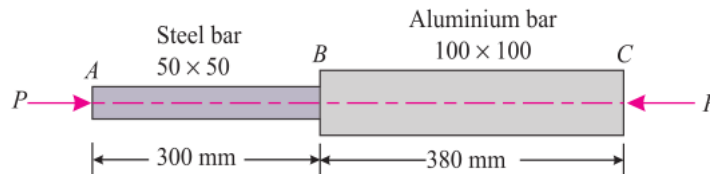

Assuming that the bars are prevented from buckling sidewise, calculate the magnitude of force P, that will cause the total length of the member to decrease by 0.25 mm. The values of elastic modulus for steel and aluminium are 210 GPa and 70 GPa respectively.

SOLUTION .

Given data:

Decrease in length (δl) = 0.25 mm,

Modulus of elasticity for steel (E_S) = 210 GPa = 210×10^3 N/mm²,

Modulus of elasticity for aluminium (E_A) = 70 GPa = 70×10^3 N/mm²

Area of steel section (A_S) = $50 \times 50 = 2500$ mm²

Area of aluminium section (A_A) = $100 \times 100 = 10000$ mm²

Length of steel section (l_S) = 300 mm and

length of aluminium section (l_A) = 380 mm.

Let P = Magnitude of the force in kN.

We know that decrease in the length of the member (δl),

$$\begin{aligned}0.25 &= P \left(\frac{l_S}{A_S E_S} + \frac{l_A}{A_A E_A} \right) \\ &= P \left(\frac{300}{2500 \times (210 \times 10^3)} + \frac{380}{10000 \times (70 \times 10^3)} \right) \\ &= \frac{780P}{700 \times 10^6}\end{aligned}$$

$$\therefore P = \frac{0.25 \times (700 \times 10^6)}{780} = 224.4 \times 10^3 \text{ N} = 224.4 \text{ KN.}$$

PROBLEM

A 6 m long hollow bar of circular section has 140 mm diameter for a length of 4 m, while it has 120 mm diameter for a length of 2 m. The bore diameter is 80 mm throughout as shown in Fig.

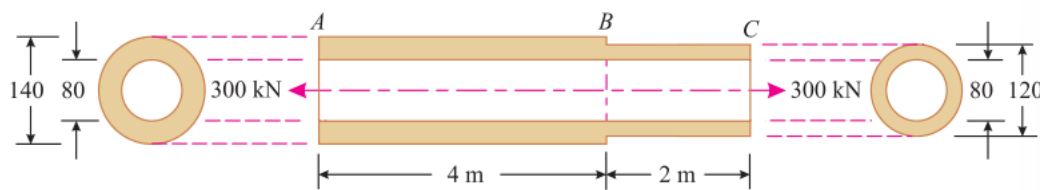

Find the elongation of the bar, when it is subjected to an axial tensile force of 300 kN. Take modulus of elasticity for the bar material as 200 GPa.

PROBLEM

A compound bar ABC 1.5 m long is made up of two parts of aluminium and steel and that cross-sectional area of aluminium bar is twice that of the steel bar. The rod is subjected to an axial tensile load of 200 kN. If the elongations of aluminium and steel parts are equal, find the lengths of the two parts of the compound bar. Take E for steel as 200 GPa and E for aluminium as one-third of E for steel.

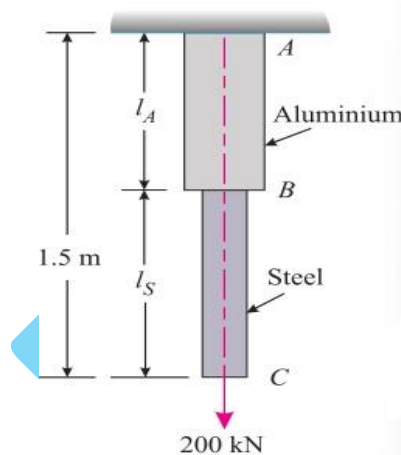

PROBLEM.

An alloy circular bar ABCD 3 m long is subjected to a tensile force of 50 kN as shown in figure.

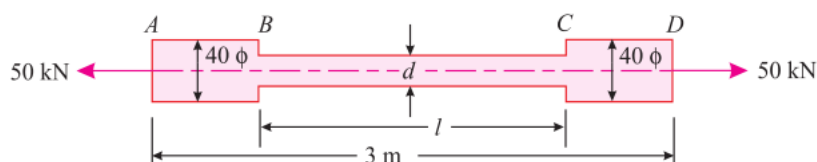

If the stress in the middle portion BC is not to exceed 150 MPa, then what should be its diameter? Also find the length of the middle portion, if the total extension of the bar should not exceed by 3 mm. Take E as 100 GPa.

PROBLEM

A steel bar ABCD 4 m long is subjected to forces as shown in Fig.

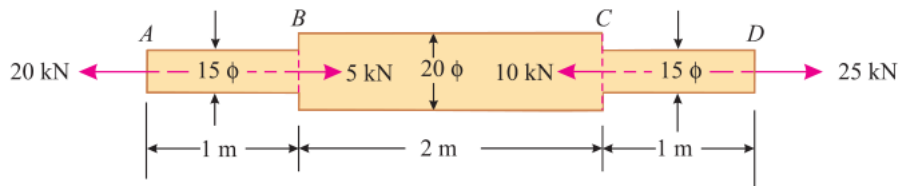

Find the elongation of the bar. Take E for the steel as 200 GPa.

SOLUTION .

Given data :

Total length of steel bar (L) = 4 m = 4×10^3 mm

Length of first part (l_1) = 1 m = 1×10^3 mm

Diameter of first part (d_1) = 15 mm

Length of second part (l_2) = 2 m = 2×10^3 mm

Diameter of second part (d_2) = 20 mm

Length of third part (l_3) = 1 m = 1×10^3 mm

Diameter of third part (d_3) = 15 mm and

modulus of elasticity (E) = 200 GPa = 200×10^3 N/mm² .

We know that area of the first and third parts of the bar,

$$A_1 = A_3 = \frac{\pi}{4} \times (d_1)^2 = \frac{\pi}{4} \times (15)^2 = 177 \text{ mm}^2$$

and area of the middle part of the bar

$$\begin{aligned} A_2 &= \frac{\pi}{4} \times (d_2)^2 = \\ &= \frac{\pi}{4} \times (20)^2 = 314 \text{ mm}^2 \end{aligned}$$

For the sake of simplification, the force of 25 kN acting at D may be split up into two forces of 15 kN and 10 kN respectively. Similarly the force of 20 kN acting at A may also be split up into two forces of 15 kN and 5 kN respectively.

Now it will be seen that the bar ABCD is subjected to a tensile force of 15 kN, part BC is subjected to a compressive force of 5 kN and the part CD is subjected to a tensile force of 10 kN as shown in Fig.

We know that elongation of the bar ABCD due to a tensile force of 15 kN,

$$\delta l_1 = \frac{P}{E} \left(\frac{l_1}{A_1} + \frac{l_2}{A_2} + \frac{l_3}{A_3} \right)$$

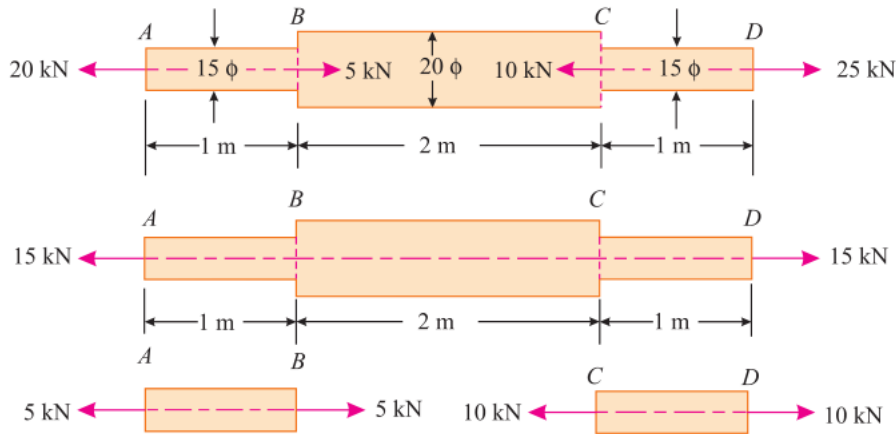

$$= \frac{15 \times 10^3}{200 \times 10^3} \left(\frac{1 \times 10^3}{177} + \frac{2 \times 10^3}{314} + \frac{1 \times 10^3}{177} \right) \text{ mm} = 1.32 \text{ mm}$$

Similarly elongation of the bar AB due to a compression force of 5 kN,

$$\delta l_2 = \frac{P_2 l_1}{A_1 E} = \frac{(5 \times 10^3) \times (1 \times 10^3)}{177 \times (200 \times 10^3)} = 0.14 \text{ mm}$$

and elongation of the bar CD due to a tensile force of 10 kN,

$$\delta l_3 = \frac{P_3 l_3}{A_3 E} = \frac{(10 \times 10^3) \times (1 \times 10^3)}{177 \times (200 \times 10^3)} = 0.3 \text{ mm}$$

∴ Total elongation of the bar ABCD,

$$\delta l = \delta l_1 + \delta l_2 + \delta l_3 = 1.43 + 0.14 + 0.28 = 1.85 \text{ mm}$$

Stresses in the Bars of Uniformly Tapering Circular Sections

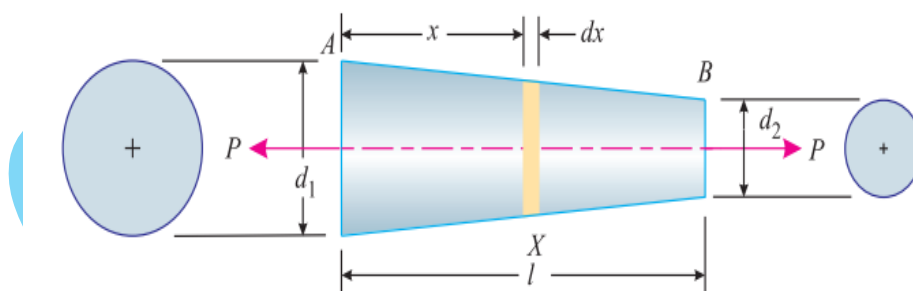

Consider a circular bar AB of uniformly tapering circular section as shown in Fig.

Let P = Pull on the bar.

l = Length of the bar,

d_1 = Diameter of the bigger end of the bar,

and d_2 = Diameter of the smaller end of the bar.

Now consider a small element of length dx of the bar, at a distance x from the bigger end as shown in Fig.

We know that diameter of the bar at a distance x , from the left end A,

$$dx = d_1 - (d_1 - d_2) \frac{x}{l} = d_1 - kx, \quad (\text{where } k = \frac{d_1 - d_2}{l})$$

and cross-sectional area of the bar at this section,

$$A_x = \frac{\pi}{4} (dx)^2 = \frac{\pi}{4} (d_1 - kx)^2$$

$$\therefore \text{Stress, } \sigma_x = \frac{P}{\frac{\pi}{4} (d_1 - kx)^2} = \frac{4P}{\pi (d_1 - kx)^2}$$

$$\text{And strain, } e_x = \frac{\text{Stress}}{E} = \frac{\frac{4P}{\pi (d_1 - kx)^2}}{E} = \frac{4P}{\pi (d_1 - kx)^2 E}$$

\therefore Elongation of the elementary length

$$= e_x \cdot dx = \frac{4P \cdot dx}{\pi (d_1 - kx)^2 E}$$

Total extension of the bar may be found out by integrating the above equation between the limit 0 and l. Therefore total elongation,

$$\begin{aligned} \delta l &= \int_0^l \frac{4P \cdot dx}{\pi (d_1 - kx)^2 E} \\ &= \frac{4P}{\pi E} \int_0^l \frac{dx}{(d_1 - kx)^2} \\ &= \frac{4P}{\pi E} \left[\frac{(d_1 - kx)^{-1}}{-1 \times -k} \right]_0^l \\ &= \frac{4P}{\pi E k} \left[\frac{1}{d_1 - kx} \right]_0^l \\ &= \frac{4P}{\pi E k} \left[\frac{1}{d_1 - kl} - \frac{1}{d_1} \right] \end{aligned}$$

Substituting the value of $k = \frac{d_1 - d_2}{l}$ in the above equation,

$$\begin{aligned} \delta l &= \frac{4P}{\pi E \frac{(d_1 - d_2)}{l}} \left[\frac{1}{d_1 - \frac{(d_1 - d_2)}{l} l} - \frac{1}{d_1} \right] \\ &= \frac{4Pl}{\pi E (d_1 - d_2)} \left[\frac{1}{d_2} - \frac{1}{d_1} \right] \\ &= \frac{4Pl}{\pi E (d_1 - d_2)} \left[\frac{d_1 - d_2}{d_2 d_1} \right] \\ &= \frac{4Pl}{\pi E d_2 d_1} \end{aligned}$$

PROBLEM

A circular alloy bar 2 m long uniformly tapers from 30 mm diameter to 20 mm diameter. Calculate the elongation of the rod under an axial force of 50 kN. Take E for the alloy as 140 GPa.

SOLUTION.

Given :

Length of bar (l) = 2 m = 2×10^3 mm

Diameter of section 1 (d_1) = 30 mm

Diameter of section 2 (d_2) = 20 mm

Axial force (P) = 50 kN = 50×10^3 N

and modulus of elasticity (E) = 140 GPa = 140×10^3 N/mm².

We know that elongation of the rod,

$$\begin{aligned} \delta l &= \frac{4Pl}{\pi E d_2 d_1} \\ &= \frac{4 \times (50 \times 10^3) \times (2 \times 10^3)}{\pi \times (140 \times 10^3) \times 30 \times 20} \\ &= 1.52 \text{ mm} \end{aligned}$$

Shear Force

The shear force (briefly written as S.F.) at the cross-section of a beam may be defined as the unbalanced vertical force to the right or left of the section.

Bending Moment

The bending moment (briefly written as B.M.) at the cross-section of a beam may be defined as the algebraic sum of the moments of the forces, to the right or left of the section.

Sign Conventions

We find different sign conventions in different books, regarding shear force and bending moment at a section. But in this book the following sign conventions will be used, which are widely followed and internationally recognised.

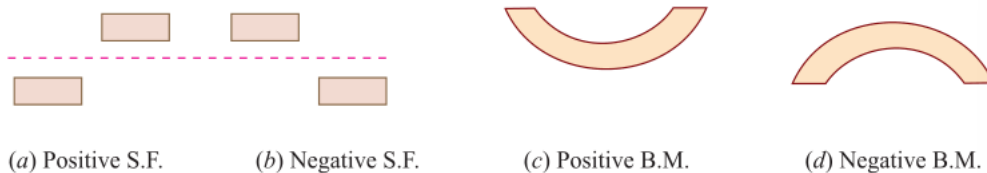

1. Shear Force. We know that as the shear force is the unbalanced vertical force, therefore it tends to slide one portion of the beam, upwards or downwards with respect to the other. The shear force is said to be positive, at a section, when the left hand portion tends to slide downwards or the right hand portion tends to slide

upwards shown in Fig. Or in other words, all the downward forces to the left of the section cause positive shear and those acting upwards cause negative shear as shown in Fig.

Similarly, the shear force, is said to be negative at a section when the left hand portion tends to slide upwards or the right hand portion tends to slide downwards as shown in Fig. Or in other words, all the upward forces to the left of the section cause negative shear and those acting downwards cause positive shear as shown in Fig.

2. Bending Moment. At sections, where the bending moment, is such that it tends to bend the beam at that point to a curvature having concavity at the top, as shown in Fig. is taken as positive. On the other hand, where the bending moment is such that it tends to bend the beam at that point to a curvature having convexity at the top, as shown in Fig. is taken as negative. The positive bending moment is often called sagging moment and negative as hogging moment.

A little consideration will show that the bending moment is said to be positive, at a section, when it is acting in an anticlockwise direction to the right and negative when acting in a clockwise direction. On the other hand, the bending moment is said to be negative when it is acting in a clockwise direction to the left and positive when it is acting in an anticlockwise direction.

Types of beam

Depending upon the type of supports beams are classified as follows:

1. Cantilever.

A cantilever is a beam whose one end is fixed and the other end free. Fig. shows a cantilever with end A rigidly fixed into its support and the other end B free. The length between A and B is known as the length of cantilever.

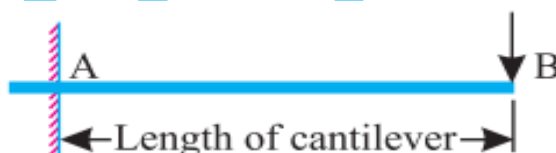

2. Simply (or freely) supported beam.

A simply supported beam is one whose ends freely rest on walls or columns or knife edges. In all such cases, the reactions are always upwards.

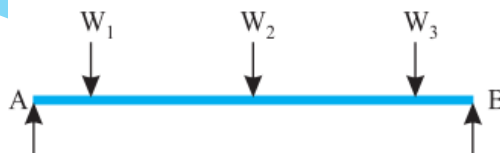

3. Overhanging beam.

An overhanging beam is one in which the supports are not situated at the ends i.e. one or both the ends project beyond the supports. In Fig. C and D are two supports and both the ends A and B of the beam are overhanging beyond the supports C and D respectively.

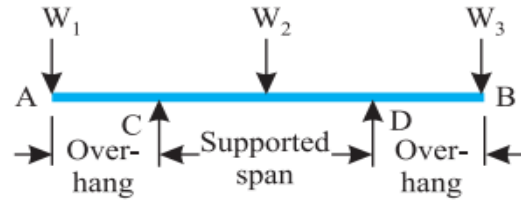

4. Fixed beam.

A fixed beam is one whose both ends are rigidly fixed or built in into its supporting walls or columns .

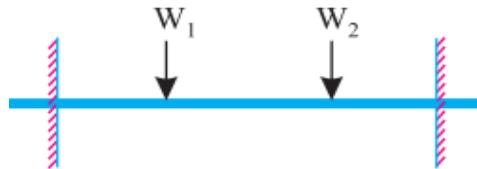

5. Continuous beam.

A continuous beam is one which has more than two supports . The supports at the extreme left and right are called the end supports and all the other supports, except the extreme, are called intermediate supports.

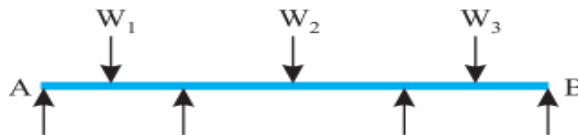

Types of loading

Point load.

A point load or concentrated load is one which is considered to act at a point. In actual practice, the load has to be distributed over a small area because such small knife-edge contacts are generally neither possible nor desirable.

Distributed load.

A distributed load is one which is distributed or spread in some manner over the length of the beam. If the spread is uniform (i.e. at the uniform rate, say w kN/metre run) it is said to be uniformly distributed load and is abbreviated as U.D.L. If the spread is not at uniform rate, it is said to be non-uniformly distributed load. Triangular and Trapezium distributed loads fall under this category.

Relation between Loading, Shear Force and Bending Moment

The following relations between loading, shear force and bending moment at a point or between any two sections of a beam are important from the subject point of view:

1. If there is a point load at a section on the beam, then the shear force suddenly changes (i.e., the shear force line is vertical). But the bending moment remains the same.
2. If there is no load between two points, then the shear force does not change (i.e., shear force line is horizontal). But the bending moment changes linearly (i.e., bending moment line is an inclined straight line).

3. If there is a uniformly distributed load between two points, then the shear force changes linearly (i.e., shear force line is an inclined straight line). But the bending moment changes according to the parabolic law. (i.e., bending moment line will be a parabola).

4. If there is a uniformly varying load between two points then the shear force changes according to the parabolic law (i.e., shear force line will be a parabola). But the bending moment changes according to the cubic law.

Cantilever with a Point Load at its Free End

Consider a *cantilever AB of length l and carrying a point load W at its free end B as shown in Fig. We know that shear force at any section X, at a distance x from the free end, is equal to the total unbalanced vertical force. i.e.

$$F_x = -W \quad (\text{Minus sign due to right downward})$$

and bending moment at this section,

$$M_x = -W \cdot x \quad (\text{Minus sign due to hogging})$$

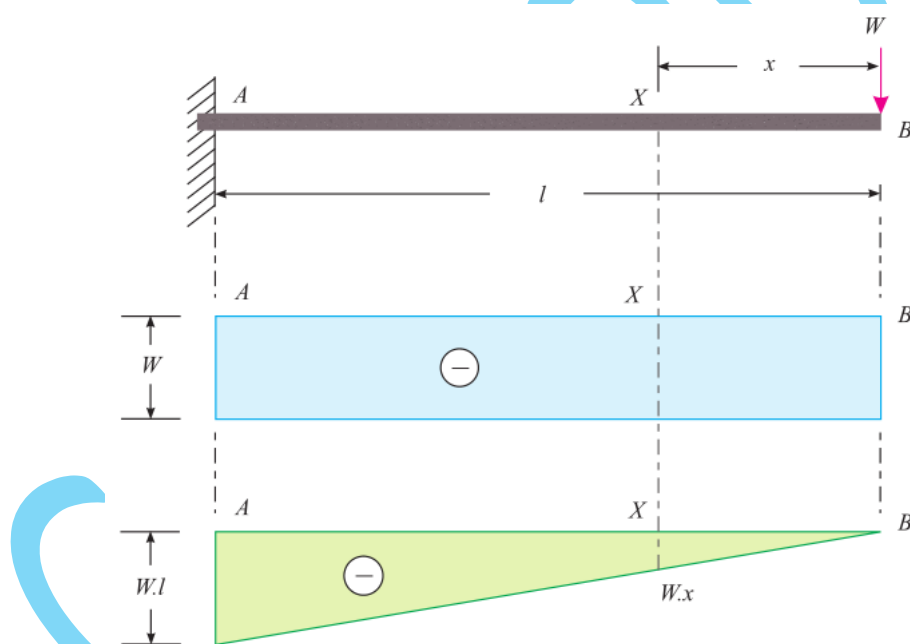

Thus from the equation of shear force, we see that the shear force is constant and is equal to $-W$ at all sections between B and A. And from the bending moment equation, we see that the bending moment is zero at B (where $x = 0$) and increases by a straight line law to $-Wl$; at (where $x = l$). Now draw the shear force and bending moment diagrams as shown in Fig.

PROBLEM.

Draw shear force and bending moment diagrams for a cantilever beam of span 1.5 m carrying point loads as shown in Fig.

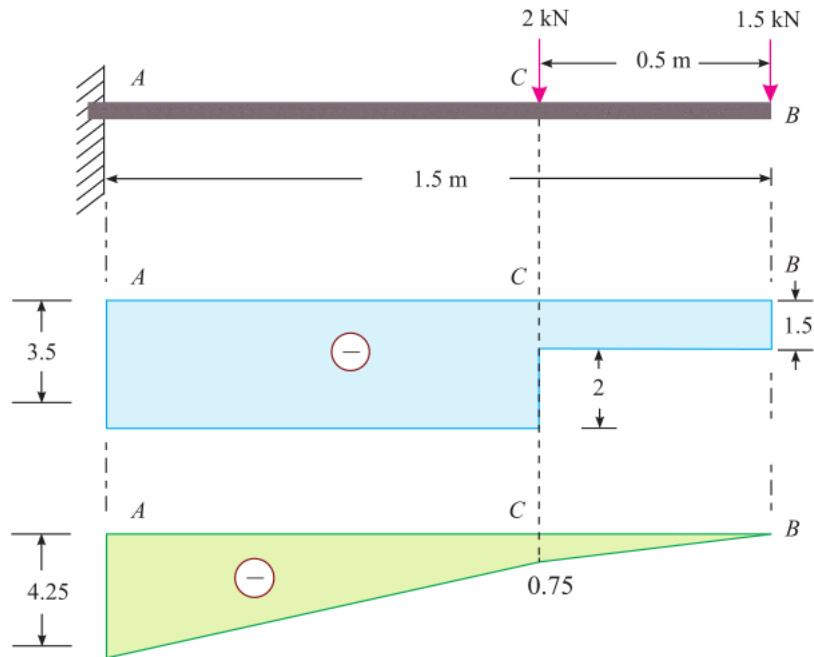

SOLUTION .

Given : Span (l) = 1.5 m

Point load at B (W_1) = 1.5 kN and point load at C (W_2) = 2 kN.

Shear force diagram

The shear force diagram is shown in Fig. and the values are tabulated here:

$$F_B = -W_1 = -1.5 \text{ kN}$$

$$F_C = -(1.5 + W_2) = -(1.5 + 2) = -3.5 \text{ kN}$$

$$F_A = -3.5 \text{ kN}$$

Bending moment diagram

The bending moment diagram is shown in Fig. and the values are tabulated here:

$$M_B = 0$$

$$M_C = -[1.5 \times 0.5] = -0.75 \text{ kN-m}$$

$$M_A = -[(1.5 \times 1.5) + (2 \times 1)] = -4.25 \text{ kN-m}$$

Cantilever with a Uniformly Distributed Load

Consider a cantilever AB of length l and carrying a uniformly distributed load of w per unit length, over the entire length of the cantilever as shown in Fig..

We know that shear force at any section X, at a distance x from B,

$$F_x = -w \cdot x \quad \dots \text{ (Minus sign due to right downwards)}$$

Thus we see that shear force is zero at B (where $x = 0$) and increases by a straight line law to $-wl$ as shown in figure.

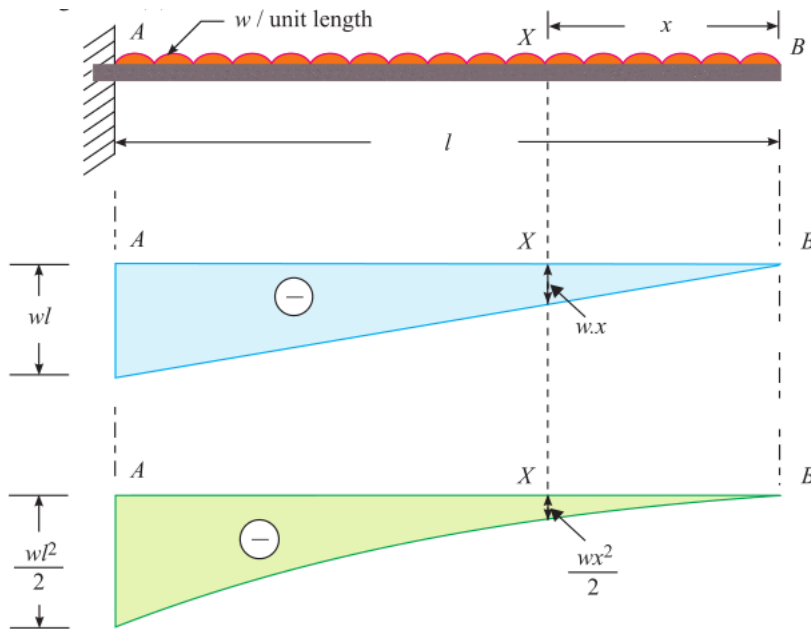

We also know that bending moment at X,

$$M_x = -wx \cdot \frac{x}{2} = -\frac{wx^2}{2} \dots\dots(\text{Minus sign due to hogging})$$

Thus we also see that the bending moment is zero at B (where $x = 0$) and increases in the form of a parabolic curve to $-\frac{wl^2}{2}$ at A (where $x = l$) as shown in Fig.

PROBLEM

A cantilever beam AB, 2 m long carries a uniformly distributed load of 1.5 kN/m over a length of 1.6 m from the free end. Draw shear force and bending moment diagrams for the beam.

SOLUTION .

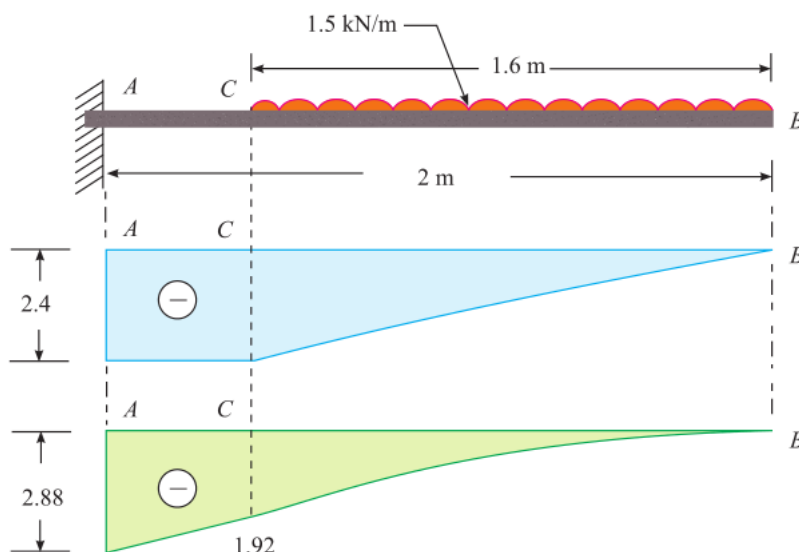

Given : span (l) = 2 m

Uniformly distributed load (w) = 1.5 kN/m and

length of the cantilever CB carrying load (a) = 1.6 m.

Shear force diagram

The shear force diagram is shown in Fig. and the values are tabulated here:

$$F_B = 0$$

$$F_C = -w \cdot a = -1.5 \times 1.6 = -2.4 \text{ kN}$$

$$F_A = -2.4 \text{ kN}$$

Bending moment diagram

The bending moment diagram is shown in Fig. and the values are tabulated here:

$$M_B = 0$$

$$M_C = -\frac{w a^2}{2} = \frac{1.5 \times (1.6)^2}{2} = -1.92 \text{ KN-m}$$

$$M_A = -\left[(1.5 \times 1.6) \left(0.4 + \frac{1.6}{2} \right) \right] = -2.88 \text{ KN-m}$$

PROBLEM

A cantilever beam of 1.5 m span is loaded as shown in Fig. Draw the shear force and bending moment diagrams.

SOLUTION .

Given : Span (l) = 1.5 m

Point load at B (W) = 2 kN

Uniformly distributed load(w) = 1 kN/m and

length of the cantilever AC carrying the load (a) = 1 m.

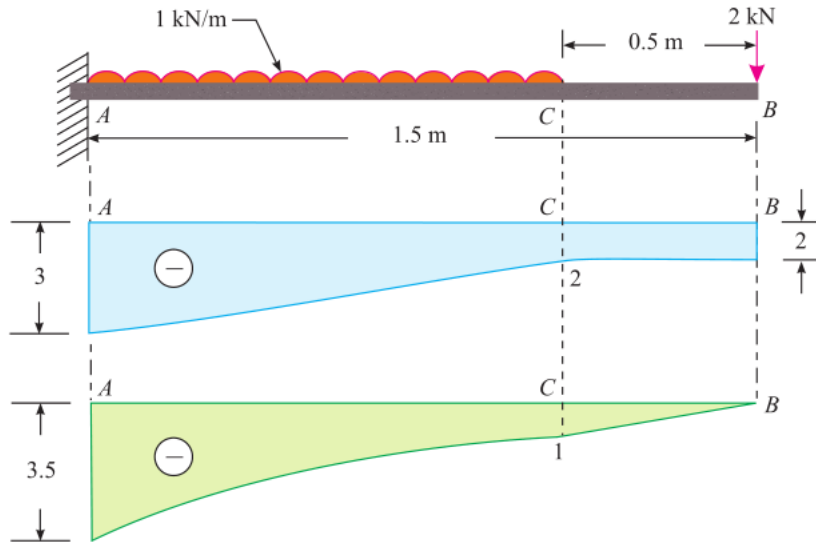

Shear force diagram

The shear force diagram is shown in Fig. and the values are tabulated here:

$$F_B = -W = -2 \text{ kN}$$

$$F_C = -2 \text{ kN}$$

$$F_A = -[2 + (1 \times 1)] = -3 \text{ kN}$$

Bending moment diagram

The bending moment diagram is shown in Fig. and the values are tabulated here:

$$M_B = 0$$

$$M_C = -[2 \times 0.5] = -1 \text{ kN-m}$$

$$M_A =$$

$$= -\left[(2 \times 1.5) + (1 \times 1) \times \frac{1}{2}\right]$$

$$= -3.5 \text{ kN-m}$$

Simply Supported Beam with a Point Load at its Mid-point

Consider a *simply supported beam AB of span l and carrying a point load W at its mid-point C as shown in Fig. Since the load is at the mid-point of the beam, therefore the reaction at the support A,

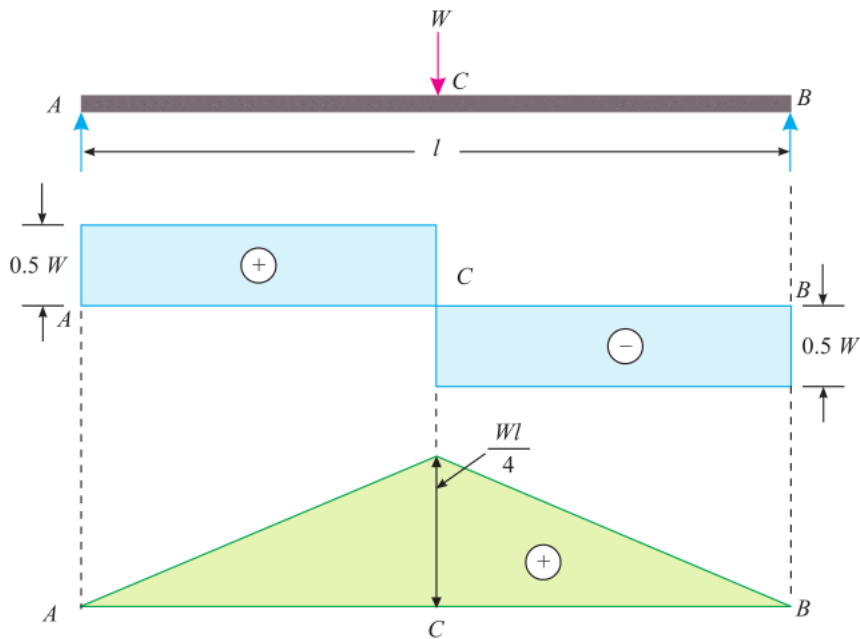

Thus we see that the shear force at any section between A and C (i.e., up to the point just before the load W) is constant and is equal to the unbalanced vertical force, i.e., $+0.5W$. Shear force at any section between C and B (i.e., just after the load W) is also constant and is equal to the unbalanced vertical force, i.e., $-0.5W$ as shown in Fig.

We also see that the bending moment at A and B is zero. It increases by a straight line law and is maximum at centre of beam, where shear force changes sign as shown in Fig.

Therefore bending moment at C,

$$M_C = \frac{W}{2} \times \frac{l}{2} = \frac{Wl}{4} \quad \text{..(Plus sign due to sagging)}$$

PROBLEM

A simply supported beam AB of span 2.5 m is carrying two point loads as shown in figure.

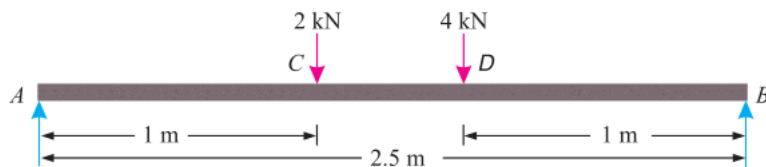

Draw the shear force and bending moment diagrams for the beam.

SOLUTION

Given :

Span (l) = 2.5 m

Point load at C (W_1) = 2 kN and

point load at B (W_2) = 4 kN.

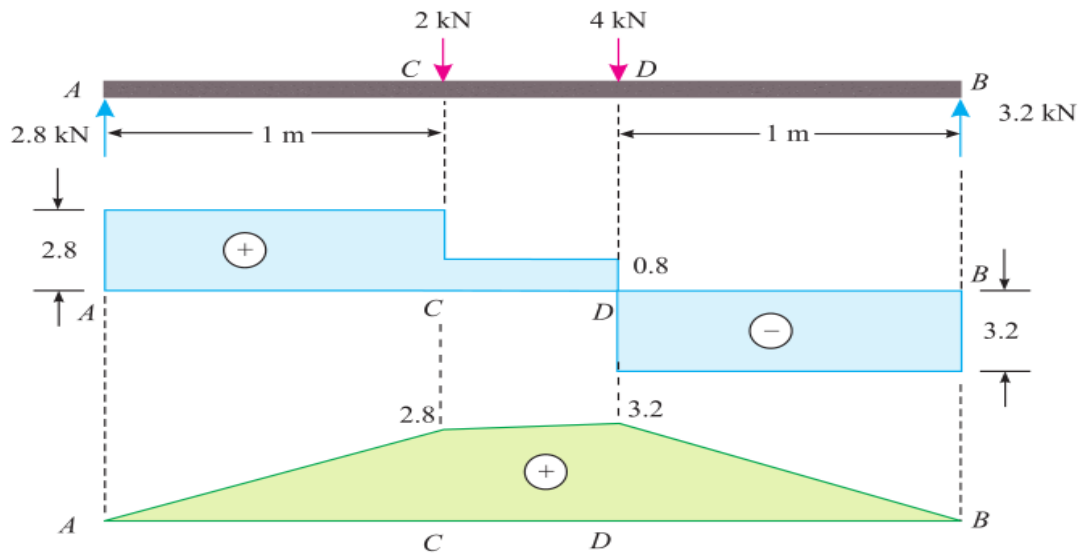

First of all let us find out the reactions R_A and R_B . Taking moments about A and equating the same,

$$R_B \times 2.5 = (2 \times 1) + (4 \times 1.5) = 8$$

$$R_B = 8/2.5 = 3.2 \text{ kN}$$

$$\text{and } R_A = (2 + 4) - 3.2 = 2.8 \text{ kN}$$

Shear force diagram

The shear force diagram is shown in Fig. and the values are tabulated here:

$$F_A = + R_A = 2.8 \text{ kN}$$

$$F_C = + 2.8 - 2 = 0.8 \text{ kN}$$

$$F_D = 0.8 - 4 = - 3.2 \text{ kN}$$

$$F_B = - 3.2 \text{ kN}$$

Bending moment diagram

The bending moment diagram is shown in Fig. 13.14 (c) and the values are tabulated here:

$$M_A = 0$$

$$M_C = 2.8 \times 1 = 2.8 \text{ kN-m}$$

$$M_D = 3.2 \times 1 = 3.2 \text{ kN-m}$$

$$M_B = 0$$

Simply Supported Beam with a Uniformly Distributed Load

Consider a simply supported beam AB of length l and carrying a uniformly distributed load of w per unit length as shown in Fig. Since the load is uniformly

distributed over the entire length of the beam, therefore the reactions at the supports A,

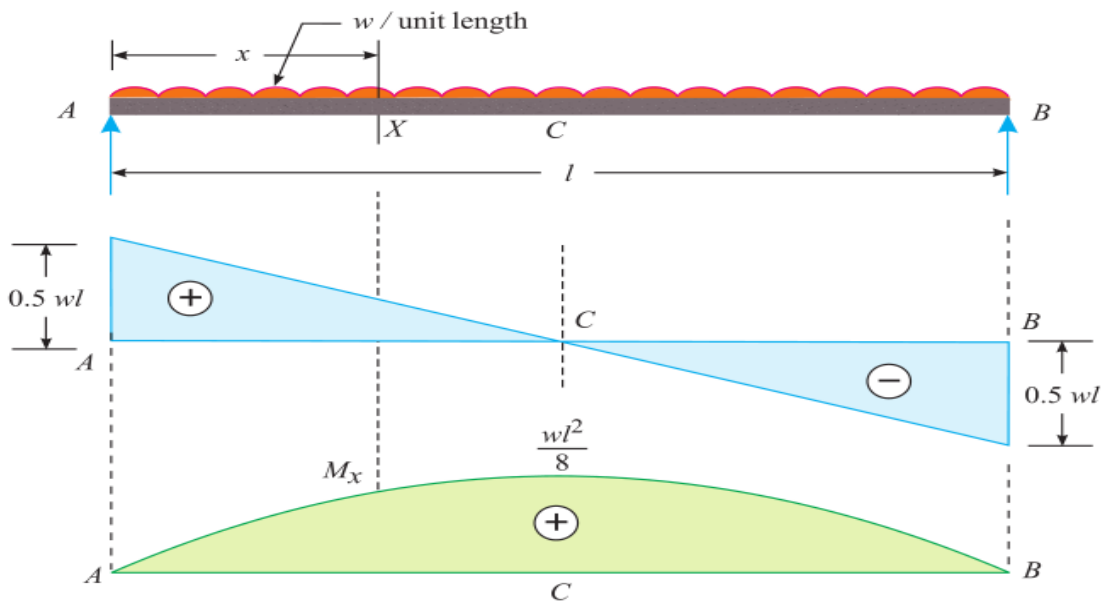

$$R_A = R_B = \frac{wl}{2} = 0.5wl$$

We know that shear force at any section X at a distance x from A,

$$F_x = R_A - wx = 0.5wl - wx$$

We see that the shear force at A is equal to $R_A = 0.5wl$, where $x = 0$ and decreases uniformly by a straight line law, to zero at the mid-point of the beam; beyond which it continues to decrease uniformly to $-0.5wl$ at B i.e., R_B as shown in Fig.

$$M_x = R_A \cdot x - \frac{wx^2}{2} = \frac{wl}{2}x - \frac{wx^2}{2}$$

We also see that the bending moment is zero at A and B (where $x = 0$ and $x = l$) and increases in the form of a parabolic curve at C, i.e., mid-point of the beam where shear force changes sign as shown in Fig. Thus bending moment at C,

$$M_C = \frac{wl}{2} \left(\frac{l}{2} \right) - \frac{w}{2} \left(\frac{l}{2} \right)^2 = \frac{wl^2}{4} - \frac{wl^2}{8} = \frac{wl^2}{8}$$

PROBLEM

A simply supported beam 6 m long is carrying a uniformly distributed load of 5 kN/m over a length of 3 m from the right end. Draw the S.F. and B.M. diagrams for the beam and also calculate the maximum B.M. on the section.

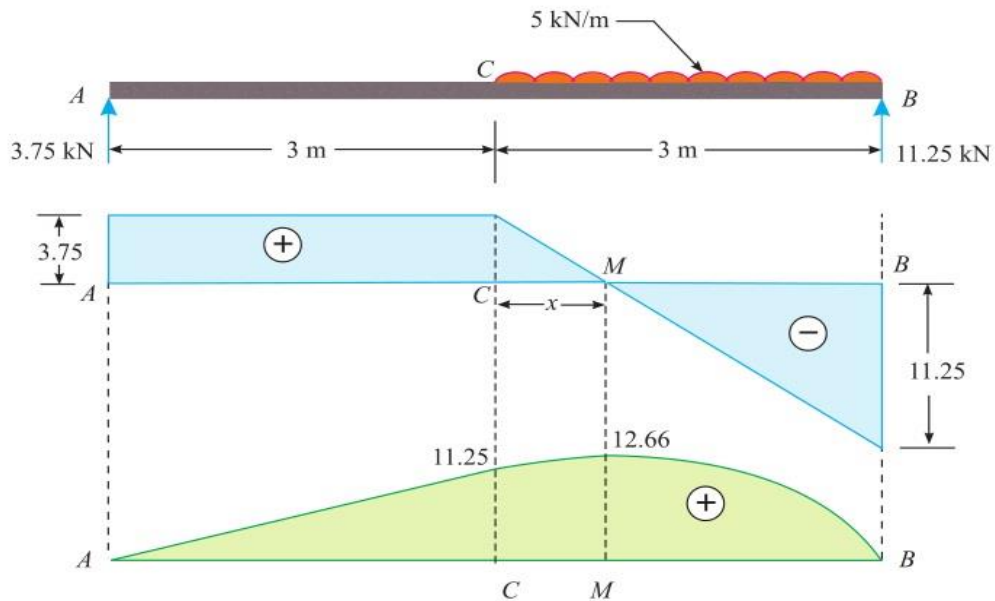

SOLUTION .

Given :

Span (l) = 6 m

Uniformly distributed load (w) = 5 kN/m and

length of the beam CB carrying load (a) = 3 m.

First of all, let us find out the reactions R_A and R_B . Taking moments about A and equating the same,

$$R_B \times 6 = (5 \times 3) \times 4.5 = 67.5$$

$$\therefore R_B = \frac{67.5}{6} = 11.25 \text{ kN}$$

and $R_A = (5 \times 3) - 11.25 = 3.75 \text{ kN}$

Shear force diagram

The shear force diagram is shown in Fig. and the values are tabulated here:

$$F_A = + R_A = + 3.75 \text{ kN}$$

$$F_C = + 3.75 \text{ kN}$$

$$F_B = + 3.75 - (5 \times 3) = - 11.25 \text{ kN}$$

Bending moment diagram

The bending moment is shown in Fig. and the values are tabulated here:

$$M_A = 0$$

$$M_C = 3.75 \times 3 = 11.25 \text{ kN}$$

$$M_B = 0$$

We know that the maximum bending moment will occur at M, where the shear force changes sign. Let x be the distance between C and M. From the geometry of the figure between C and B, we find that

$$\frac{x}{3.75} = \frac{3-x}{11.25}$$

or $11.25 x = 11.25 - 3.75 x$

$$15 x = 11.25$$

Or $x = 11.25/15 = 0.75 \text{ m}$

∴ $M_M = 3.75 \times (3 + 0.75) - 5 \times \frac{0.75}{2}$
 $= 12.66 \text{ kN-m}$

PROBLEM

A simply supported beam 5 m long is loaded with a uniformly distributed load of 10 kN/m over a length of 2 m as shown in Fig.

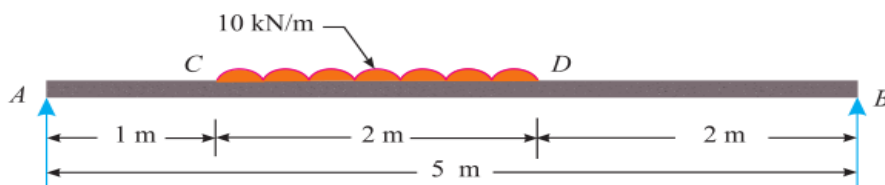

Draw shear force and bending moment diagrams for the beam indicating the value of maximum bending moment.

SOLUTION .

Given :

$$\text{Span (l)} = 5 \text{ m}$$

Uniformly distributed load (w) = 10 kN/m and
length of the beam CD carrying load (a) = 2 m.

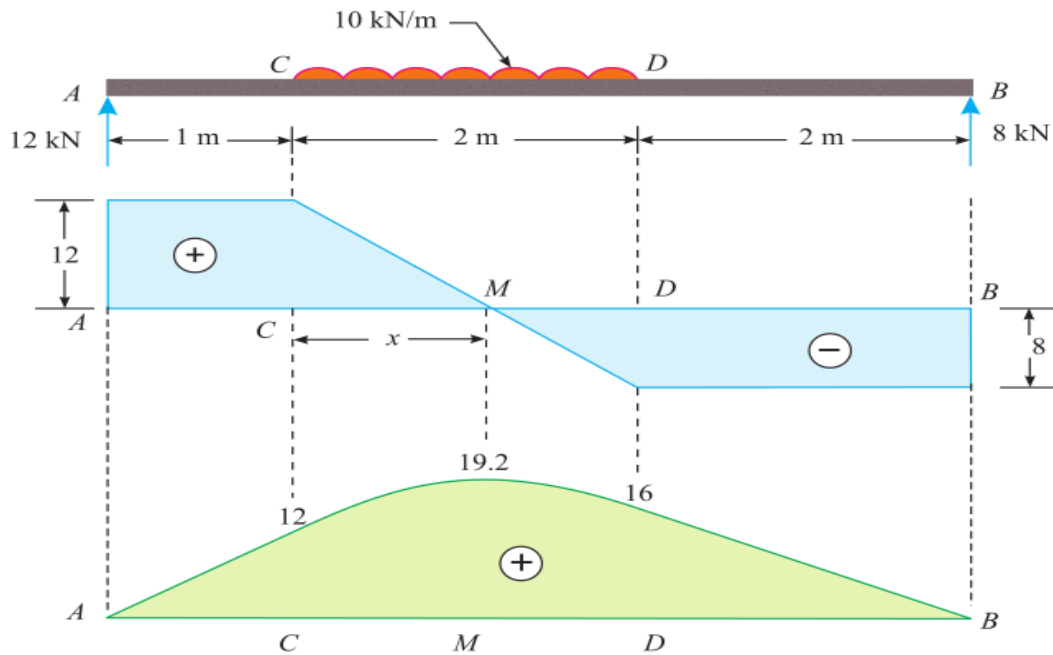

First of all, let us find out the reactions R_A and R_B . Taking moments about A and equating the same,

$$R_B \times 5 = (10 \times 2) \times 2 = 40$$

$$\therefore R_B = 40/5 = 8 \text{ kN}$$

$$\text{and } R_A = (10 \times 2) - 8 = 12 \text{ kN}$$

Shear force diagram

The shear force diagram is shown in Fig. 13.18 (b) and the values are tabulated here:

$$F_A = + R_A = + 12 \text{ kN}$$

$$F_C = + 12 \text{ kN}$$

$$F_D = + 12 - (10 \times 2) = - 8 \text{ kN}$$

$$F_B = - 8 \text{ kN}$$

Bending moment diagram

The bending moment diagram is shown in Fig. 13.18 (c) and the values are tabulated here:

$$M_A = 0$$

$$M_C = 12 \times 1 = 12 \text{ kN-m}$$

$$M_D = 8 \times 2 = 16 \text{ kN-m}$$

We know that maximum bending moment will occur at M, where the shear force changes sign.

Let x be the distance between C and M. From the geometry of the figure between C and D, we find that

$$\frac{x}{12} = \frac{2-x}{8}$$

or $8x = 24 - 12x$

$$20x = 24$$

Or $x = 24/20 = 1.2 \text{ m}$

$$M_M = 12(1 + 1.2) - 10 \times 1.2 \times \frac{1.2}{2}$$

$$= 19.2 \text{ kN-m}$$

PROBLEM

A simply supported beam of 4 m span is carrying loads as shown in Figure.

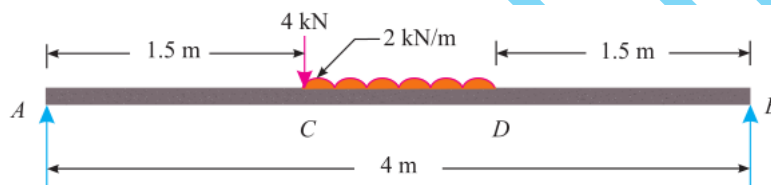

Draw shear force and bending moment diagrams for the beam.

SOLUTION

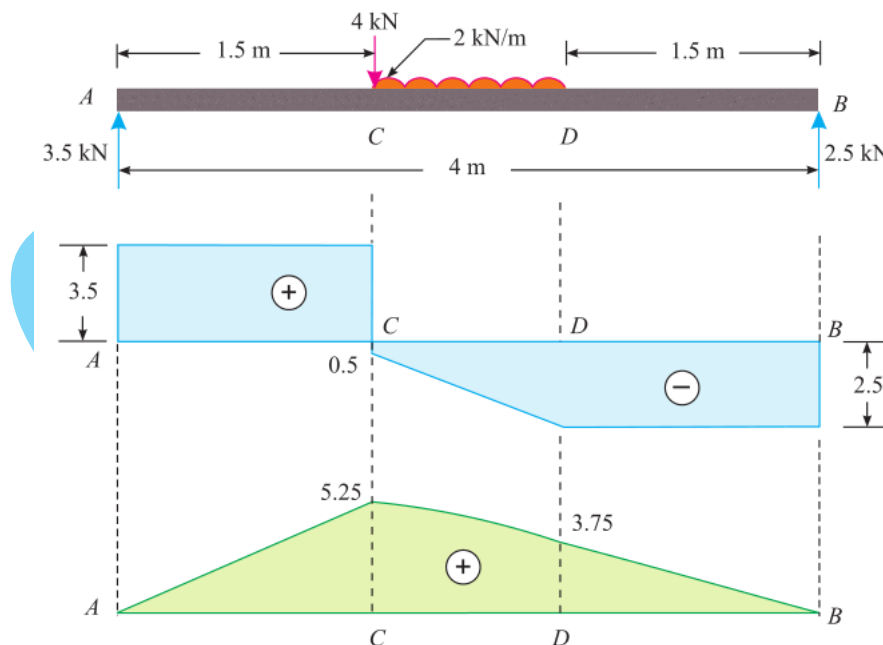

Given :

$$\text{Span (l)} = 4 \text{ m}$$

$$\text{Point load at C (W)} = 4 \text{ kN}$$

and uniformly distributed load between C and D (w) = 2 kN/m.

First of all, let us find out the reactions R_A and R_B . Taking moments about A and equating the same,

$$R_B \times 4 = (4 \times 1.5) + (2 \times 1) \times 2 = 10$$

$$R_B = 10/4 = 2.5 \text{ kN}$$

$$\text{and } R_A = 4 + (2 \times 1) - 2.5 = 3.5 \text{ kN}$$

Shear force diagram

The shear force diagram is shown in Fig. and the values are tabulated here:

$$F_A = + R_A = + 3.5 \text{ kN}$$

$$F_C = + 3.5 - 4 = - 0.5 \text{ kN}$$

$$F_D = - 0.5 - (2 \times 1) = - 2.5 \text{ kN}$$

$$F_B = - 2.5 \text{ kN}$$

Bending moment diagram

The bending moment diagram is shown in Fig. and the values are tabulated here:

$$M_A = 0$$

$$M_C = 3.5 \times 1.5 = 5.25 \text{ kN-m}$$

$$M_D = 2.5 \times 1.5 = 3.75 \text{ kN-m}$$

$$M_B = 0$$

We know that the maximum bending moment will occur at C, where the shear force changes sign, i.e., at C as shown in the figure.

PROBLEM

A simply supported beam AB, 6 m long is loaded as shown in Fig.

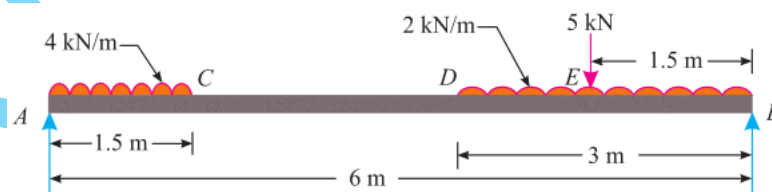

Construct the shear force and bending moment diagrams for the beam and find the position and value of maximum bending moment.

SOLUTION .

Given :

$$\text{Span } (l) = 6 \text{ m}$$

$$\text{Point load at E } (W) = 5 \text{ kN}$$

Uniformly distributed load between A and C (w_1) = 4 kN/m and uniformly distributed load between D and B = 2 kN/m.

First of all, let us find out the reactions R_A and R_B . Taking moments about A and equating the same,

$$R_B \times 6 = (4 \times 1.5 \times 0.75) + (2 \times 3 \times 4.5) + (5 \times 4.5) = 54$$

$$R_B = 54/6 = 9 \text{ kN}$$

$$\text{and } R_A = (4 \times 1.5) + (2 \times 3) + 5 - 9 = 8 \text{ kN}$$

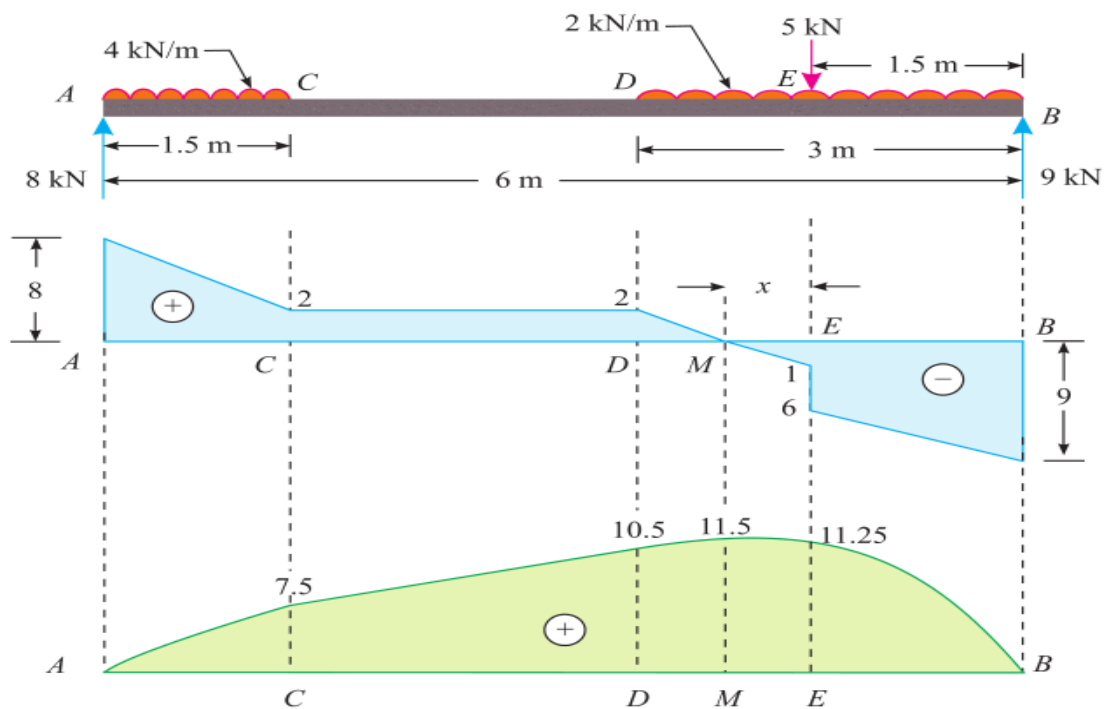

Shear force diagram

The shear force diagram is shown in Fig. and the values are tabulated here:

$$F_A = + R_A = + 8 \text{ kN}$$

$$F_C = 8 - (4 \times 1.5) = 2 \text{ kN}$$

$$F_D = 2 \text{ kN}$$

$$F_E = 2 - (2 \times 1.5) - 5 = - 6 \text{ kN}$$

$$F_B = - 6 - (2 \times 1.5) = - 9 \text{ kN}$$

Bending moment diagram

The bending moment diagram is shown in Fig. and the values are tabulated here:

$$M_A = 0$$

$$M_C = (8 \times 1.5) - (4 \times 1.5 \times 0.75) = 7.5 \text{ kN-m}$$

$$M_D = (8 \times 3) - (4 \times 1.5 \times 2.25) = 10.5 \text{ kN-m}$$

$$M_E = (9 \times 1.5) - (2 \times 1.5 \times 0.75) = 11.25 \text{ kN-m}$$

$$M_B = 0$$

We know that maximum bending moment will occur at M, where the shear force changes sign.

Let x be the distance between E and M. From the geometry of the figure between D and E, we find that

$$\frac{x}{1} = \frac{1.5-x}{2}$$

or $2x = 1.5 - x$

$$3x = 1.5$$

or $x = 1.5/3 = 0.5 \text{ m}$

$\therefore M_M = 9(1.5 + 0.5) - (2 \times 2 \times 1) - (5 \times 0.5) = 11.5 \text{ kN-m}$

Bending formula

Modulus of Section

We have already discussed in the previous article, the relation for finding out the bending stress on the extreme fibre of a section, i.e.,

$$\frac{M}{I} = \frac{\sigma}{y}$$

Or $M = \sigma \times \frac{I}{y}$

From this relation, we find that the stress in a fibre is proportional to its distance from the c.g. If y_{\max} is the distance between the c.g. of the section and the extreme fibre of the stress, then

$$M = \sigma_{\max} \times \frac{I}{y_{\max}} = \sigma_{\max} \times Z$$

Where, $Z = \frac{I}{y_{\max}}$

The term 'Z' is known as modulus of section or section modulus. The general practice of writing the above equation is $M = \sigma \times Z$, where σ denotes the maximum stress, tensile or compressive in nature.

We know that if the section of a beam is symmetrical, its centre of gravity and hence the neutral axis will lie at the middle of its depth. We shall now consider the modulus of section of the following sections:

1. Rectangular section.
2. Circular section.

1. Rectangular section

We know that moment of inertia of a rectangular section about an axis through its centre of gravity.

$$I = \frac{bd^3}{12}$$

$$\begin{aligned}\therefore \text{Modulus of section } Z &= \frac{I}{y} = \frac{bd^3}{12} \times \frac{2}{d} && (y = \frac{d}{2}) \\ &= \frac{bd^2}{6}\end{aligned}$$

2. Circular section

We know that moment of inertia of a circular section about an axis through its c.g.,

$$I = \frac{\pi}{64} (d)^4$$

$$\therefore \text{Modulus of section } Z = \frac{I}{y} = \frac{\pi}{64} (d)^4 \times \frac{2}{d} = \frac{\pi}{32} (d)^3$$

GEAR TRAIN OR TRAIN OF WHEELS

Two or more gears are made to mesh with each other, so as to operate as a single system, to transmit power from one shaft to another. Such a combination is called gear train or train of wheels. Following are the two types of train of wheels depending upon the arrangement of wheels:

1. Simple gear train.
2. Compound gear train.

1. SIMPLE GEAR TRAIN

Sometimes the distance between the two wheels is great. The motion from one wheel to another, in such a case, may be transmitted by either of the following two methods :

1. By providing a large sized wheel, or
2. By providing intermediate wheels,

Providing large wheel is very inconvenient and uneconomical; whereas providing intermediate wheels is very convenient and economical.

It may be noted that when the number of intermediate wheels is odd, the motion of both the wheels (i.e., driver and follower) is same. But, if the number of intermediate wheels is even, the motion of the follower is the opposite direction of the driver.

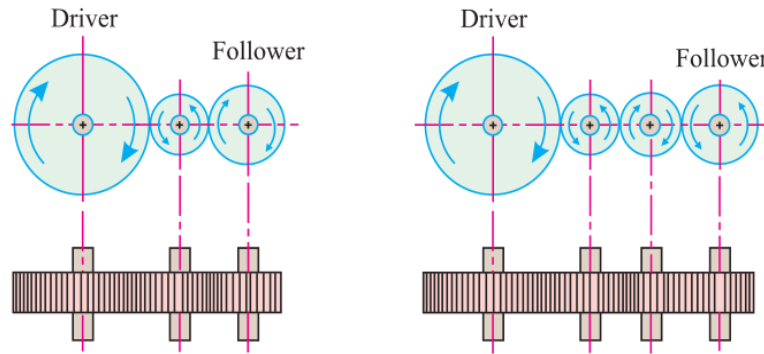

Simple gear train

Now consider a simple train of wheels with one intermediate wheel.

Let N_1 = Speed of the driver

T_1 = No. of teeth on the driver,

N_2, T_2 = Corresponding values for the intermediate wheel, and

N_3, T_3 = Corresponding values for the follower.

Since the driver gears with the intermediate wheel, therefore

$$\frac{N_2}{N_1} = \frac{T_1}{T_2} \dots\dots\dots (i)$$

Similarly, as the intermediate wheel gears with the follower, therefore

$$\frac{N_3}{N_2} = \frac{T_2}{T_3} \dots\dots\dots (ii)$$

Multiplying equation (ii) by (i),

$$\frac{N_3}{N_2} \times \frac{N_2}{N_1} = \frac{T_2}{T_3} \times \frac{T_1}{T_2}$$

Or
$$\frac{N_3}{N_1} = \frac{T_1}{T_3}$$

$$\therefore \frac{\text{Speed of the follower}}{\text{Speed of the driver}} = \frac{\text{No. of teeth on the driver}}{\text{No. of teeth on the follower}}$$

Similarly, it can be proved that the above equation also holds good, even if there are any number of intermediate wheels. It is thus obvious, that the velocity ratio, in a simple train of wheels, is independent of the intermediate wheels. These intermediate wheels are also called idle wheels, as they do not effect the velocity ratio of the system.

2. COMPOUND GEAR TRAIN

We have seen that the idle wheels, in a simple train of wheels, do not affect the velocity ratio of the system. But these wheels are useful in bridging over the space between the driver and the follower. But whenever the distance between the driver and follower has to be bridged over by intermediate wheels and at the same time a great (or much less) velocity ratio is required then the advantage of intermediate wheels is intensified by providing compound wheels on intermediate shafts. In this case, each intermediate shaft has two wheels rigidly fixed to it, so that they may have the same speed. One of these two wheels gears with the driver and the other with the follower attached to the next shaft.

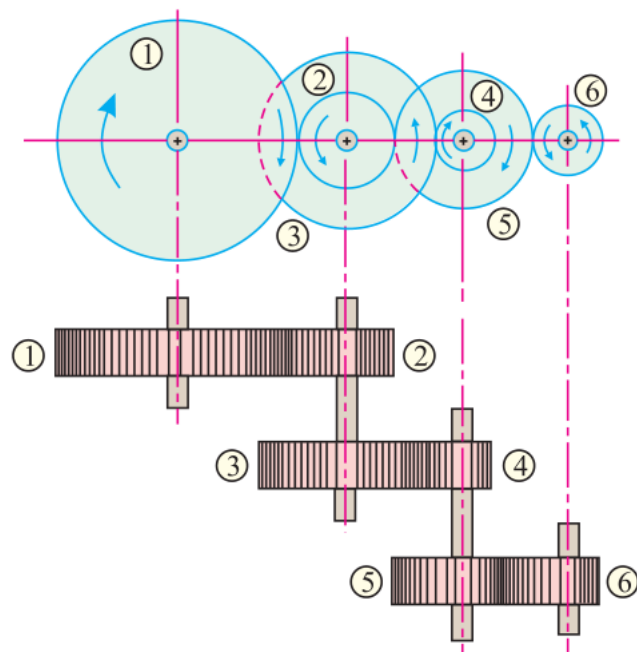

Compound gear train

Let N_1 = Speed of the driver 1

T_1 = No. of teeth on the driver 1,

Similarly, N_2, N_3, \dots, N_6 = Speed of the respective wheels.

T_2, T_3, \dots, T_6 = No. of teeth on the respective wheels.

Since the wheel 1 gears with the wheel 2, therefore

$$\frac{N_2}{N_1} = \frac{T_1}{T_2} \quad \dots\dots(i)$$

Similarly, $\frac{N_4}{N_3} = \frac{T_3}{T_4} \quad \dots\dots(ii)$

And $\frac{N_6}{N_5} = \frac{T_5}{T_6} \quad \dots\dots(iii)$

Multiplying equation (i), (ii) and (iii) we get

$$\frac{N_2}{N_1} \times \frac{N_4}{N_3} \times \frac{N_6}{N_5} = \frac{T_1}{T_2} \times \frac{T_3}{T_4} \times \frac{T_5}{T_6}$$

$$\frac{N_6}{N_1} = \frac{T_1}{T_2} \times \frac{T_3}{T_4} \times \frac{T_5}{T_6} \quad (\because N_2 = N_3 \text{ and } N_4 = N_5)$$

$$= \frac{\text{Product of teeth on the drivers}}{\text{Product of teeth on the followers}}$$

Example : The gearing of a machine tools is shown in Fig.

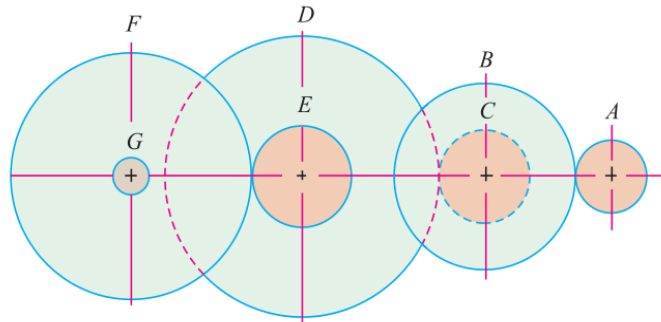

The motor shaft is connected to A and rotates at 975 r.p.m. The gear wheels B, C, D and E are fixed to parallel shafts rotating together. The final gear F is fixed on the output shaft G. What is the speed of F ? The number of teeth on each wheel is as given below :

Gear	A	B	C	D	E	F
No. of teeth	20	50	25	75	26	65

Solution: Given:

Speed of the gear wheel A (N_A) = 975 r.p.m.;

No. of teeth on wheel A (T_A) = 20;

No. of teeth on wheel B (T_B) = 50;

No. of teeth on wheel C (T_C) = 25;

No. of teeth on wheel D (T_D) = 75;

No. of teeth on wheel E (T_E) = 26

and no. of teeth on wheel F (T_F) = 65.

Let N_F = Speed of the shaft F.

We know that

$$\frac{N_F}{N_A} = \frac{T_A \times T_C \times T_E}{T_B \times T_D \times T_F}$$

$$\therefore \frac{N_F}{975} = \frac{20 \times 25 \times 26}{50 \times 75 \times 65} = \frac{4}{75}$$

$$N_F = 975 \times \frac{4}{75} = 52 \text{ r.p.m.}$$

Hydraulic coupling:-

Fluid coupling is also known as hydraulic coupling. It is a hydrodynamic device which is used to transfer rotational power from one shaft to another by the use of transmission fluid. It is used in the automotive transmission system, marine propulsion system, and in industries for power transmission. It is used as an alternative for the [mechanical clutch](#).

Main Parts

It consists of three main components

1. **Housing:** It is also known as the shell. It has oil-tight seal around the drive shaft. It also protects the impeller and turbine from outside damage.
2. **Impeller or pump:** It is a turbine which is connected to the input shaft and called as impeller. It is also known as pump because it acts as a centrifugal pump.
3. **Turbine:** It is connected to the output shaft to which the rotational power is to be transmitted. The impeller is connected to the prime mover (internal combustion engine) which is a power source. The turbine is connected to the output shaft where rotation power is needed to be transmitted. The impeller and turbine is enclosed in an oil-tight sealed housing. The housing consists of transmission fluid.

WORKING PRINCIPLE:-

The working principle of fluid can be easily explained by the taking two fans in which one is connected to the power supply and other is not. When the power switch is ON, the air from the first fan is starts to blow towards the second fan (which is not connected to the power source). Initially when the first fan is blowing at lower speed, it does not able to drive the second fan. But as the speed of the powered fan increases, the speed of air striking the blades of second fan also increases and it starts to rotate. After some time it acquires the same velocity of that of the first fan.

Working Principle

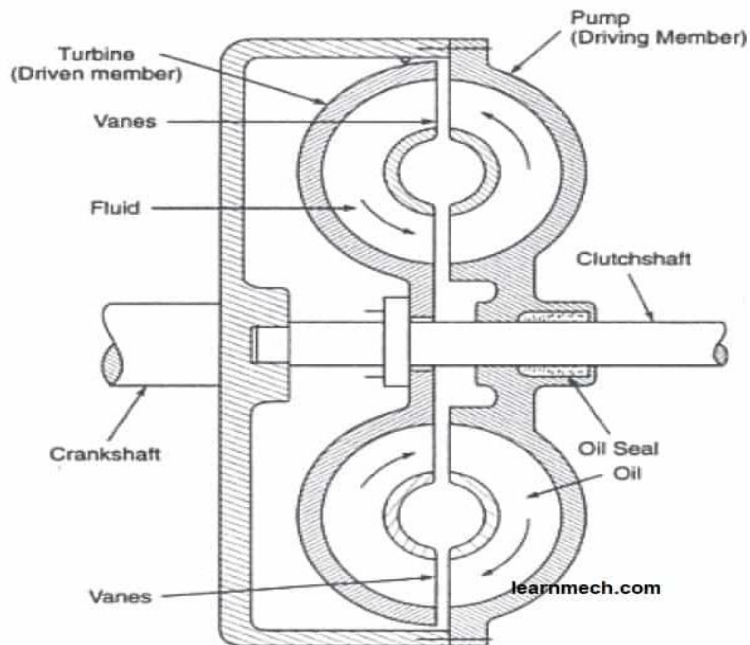

On the same principle the fluid coupling works. In that the impeller act as first fan and the turbine act as second fan. Both impeller and turbine enclosed in an oil tight housing. The impeller is connected the input shaft of the prime mover and the turbine with the output shaft. When the impeller is moved by the prime mover, the fluid in housing experiences centrifugal force and due to curved vanes of the impeller the fluid directed towards the turbine blades. As the fluid strikes the turbine blades it starts rotating. With the increase in the speed of impeller, the velocity of the turbine increases and becomes approximately equal to the impeller speed. The fluid after passing through the turbine blades again return to the impeller.

Torque converter

Torque converter is a type of fluid coupling which is used to transfer rotating power from the engine of a vehicle to the transmission. It takes place of a mechanical clutch in an automatic transmission. The main function of it is to allow the load to be isolated from the main power source. It sits in between the engine and transmission. It has the same function as the clutch in manual transmission. As the clutch separates the engine from the load when it stops, in the same way, it also isolates the engine from the load and keeps engine running when a vehicle stops.

Cars with automatic transmissions don't have clutches, so they need a way to let the engine keep running while the wheels and gears in the transmission come to a stop. Manual transmission cars use a clutch that disconnects the engine from the transmission. Automatic transmissions use a torque converter.

When the engine is idling, such as at a stoplight, the amount of torque going through the torque converter is small but still enough to require some pressure on the brake pedal to stop the car from creeping. When you release the brake and step on the

gas, the engine speeds up and pumps more fluid into the torque converter, causing more power (torque) to be transmitted to the wheels.

FUNCTIONS OF TORQUE CONVERTER

Its main functions are:

1. It transfers the power from the engine to the transmission input shaft.
2. It drives the front pump of the transmission.
3. It isolates the engine from the load when the vehicle is stationary.
4. It multiplies the torque of the engine and transmits it to the transmission. It almost doubles the output torque.

PARTS OF TORQUE CONVERTER

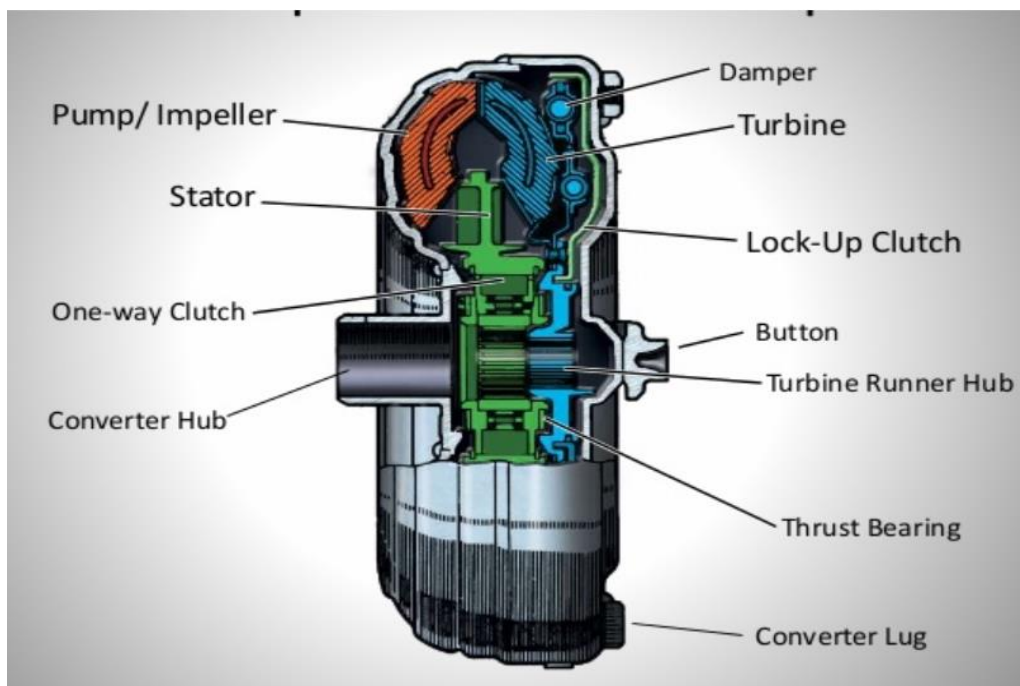

The torque converter has three main parts

1. Impeller or Pump

The impeller is connected to the housing and the housing connected to the engine shaft. It has curved and angled vanes. It rotates with the engine speed and consists of automatic transmission fluid. When it rotates with the engine, the centrifugal force makes the fluid move outward. The blades of the impeller are designed in such a way that it directs the fluid towards the turbine blades. It acts as a centrifugal pump which sucks the fluid from the automatic transmission and delivers it to the turbine.

2. Stator:

The stator is located in between the impeller and turbine. The main function of the stator is to give direction to the returning fluid from the turbine so that the fluid enters the impeller in the direction of its rotation. As the fluid enters in the direction of the impeller, it multiplies the torque. So stator helps in the torque multiplication by changing the direction of the fluid and allows it to enter in the direction of the impeller rotation. The stator changes the direction of fluid almost up to 90 degrees.

3. Turbine

The turbine is connected to the input shaft of the automatic transmission. It is present on the engine side. It also consists of curved and angled blades. The blades of the turbine are designed in such a way that it can change the direction of the fluid completely that strikes on its blades. It is the change in the direction of the fluid that forces the blades to move in the direction of the impeller. As the turbine rotates the input shaft of the transmission also rotates and made the vehicle to move. The turbine is also having a lock-up clutch at its back. The lock-up clutch comes into play when the torque converter achieves coupling point. the lockup eliminates the loses and improves the efficiency of the converter.

WORKING PRINCIPLE OF TORQUE CONVERTER

For understanding the working principle of the torque converter, let's take two fans. One fan is connected to the power source and other is not connected with the power source. When the first fan connected to the power source starts moving, the air from it flows to the second fan which is stationary. The air from the first fan strikes on the blades of the second fan and it also starts rotating almost at the same speed to the first one. When the second fan is stopped, it does not stop the first one. The first fan keeps rotating.

On the same principle, the torque converter works. In that, the impeller or pump acts as the first fan which is connected to the engine and turbine act as the second fan which is connected to the transmission system. When the engine runs, it rotates the impeller and due to the centrifugal force the oil inside the torque converter assembly directed towards the turbine. As it hits the turbine blades, the turbine starts rotating. This makes the transmission system rotate and the wheels of the vehicle move. When the engine stops, the turbine also stops rotating but the impeller connected the engine keeps moving and this prevents the killing of the engine.

It has three stages of operations

1. Stall:

During stall (stop) condition of the vehicle, the engine is applying power to the impeller but the turbine cannot rotate. This happens, when the vehicle is stationary and the driver has kept his foot on the brake paddle to prevent it from moving. During this condition maximum multiplication of torque takes place. As the driver removes its foot from the brake paddle and presses the accelerator paddle, the impeller starts moving faster and this set the turbine to

move. At this situation, there is a larger difference between the pump and turbine speed. The impeller speed is much greater than the turbine speed.

2. Acceleration:

During acceleration, the turbine speed keeps on increasing, but still, there is a large difference between the impeller and turbine speed. As the speed of the turbine increases the torque multiplication reduces. During acceleration of the vehicle the torque multiplication is less than that is achieved during a stall condition.

3. Coupling:

It is a situation when the turbine achieved approximately 90 percent speed of the impeller and this point is called the coupling point. The torque multiplication ceases and becomes zero and the torque converter behaves just like a simple fluid coupling. At the coupling point, the lock-up clutch comes into play and locks the turbine to the impeller of the converter. This puts the turbine and impeller to move at the same speed. The lock-up clutch engages only when the coupling point is achieved. During coupling, the stator also starts to rotate in the direction of the impeller and turbine rotation.

NOTE:

1. The maximum torque multiplication takes place during stalling condition.
2. The stator remains stationary before coupling point and helps in the torque multiplication. As the coupling attained, stator stops torque multiplication and starts rotating with the impeller and turbine.
3. The lock-up clutch engages when the coupling point is achieved and removes the power losses resulting in increased efficiency.

Function of fly wheel and governor:-

In running mechanical system different kinds of fluctuation and variation occurs due to various factors. These kinds of disturbances should be avoided for the accurate performance of mechanical system. The speed of the running parts varies according to loads and power input, so to make the system stable under various fluctuations we require some devices or mechanisms which may be a part of the mechanical system. Flywheel and Governor are the two mechanical devices which are used to control the different kind of variation in speed. The objective of both Governor and Flywheel is little bit same but their applications and operating mechanisms are different.

Flywheel is used to control the fluctuation of speed during the cyclic operation of the engine. It is the kind of heavy rotating wheel which is suitably attached with the crank shaft. Sometimes we can call it Energy/Power storing device because generally the mass of flywheel is quite heavy due to this it can provide large moment of inertia. In engine during the period of power stroke flywheel store the energy which is more than the requirement and release it when it requires or at the time of other than power stroke.

The function of the governor is quite different, it is used to maintain the constant speed of the running component. The speed of the engine varies due to the load so

to maintain constant speed within specific range governor comes into play. Governor maintain the constant speed by regulating the fuel supply.

GOVERNER

It is a device which used in an engine to maintain the mean speed of the engine by controlling the flow of fuel with respect to load on the engine. It means that, if the load on the engine increases then it requires more fuel to supply & in another case when the load on the engine decreases, then it requires less amount of fuel to be supplied.

WATT GOVERNER

Watt governor is the simplest form of centrifugal governors. Centrifugal governors are special type of governors with a feedback system that controls the speed of an engine by regulating the flow of fuel or working fluid.

Watt governor has two fly balls attached to two arms of negligible masses. Watt governor is used to supply the required amount of fuel at different speed. When the speed of engine increases, the supply of fuel needs to increase and as the engine speed decreases the supply of fuel should be decreased . So the fuel supply should be regulated according to the speed of the engine. With the help of watt governor we can obtain a required load on the engine with constant smooth function.

Construction :-

Watt governor consists of two fly balls which are located at the end of the arms . The upper parts of these two arms are pivoted to the spindle. This spindle is driven by the engine through the bevel gears. The lower parts of arms are connected to the sleeve which move upward or downward as the balls moves upward or downward . The sleeve has stopper which are placed at up and down of sleeve to limit its movement. The sleeve is connected to throttle valve through bell crank lever . The movement of sleeve controls opening and closing of throttle valve.



WATT GOVERNOR

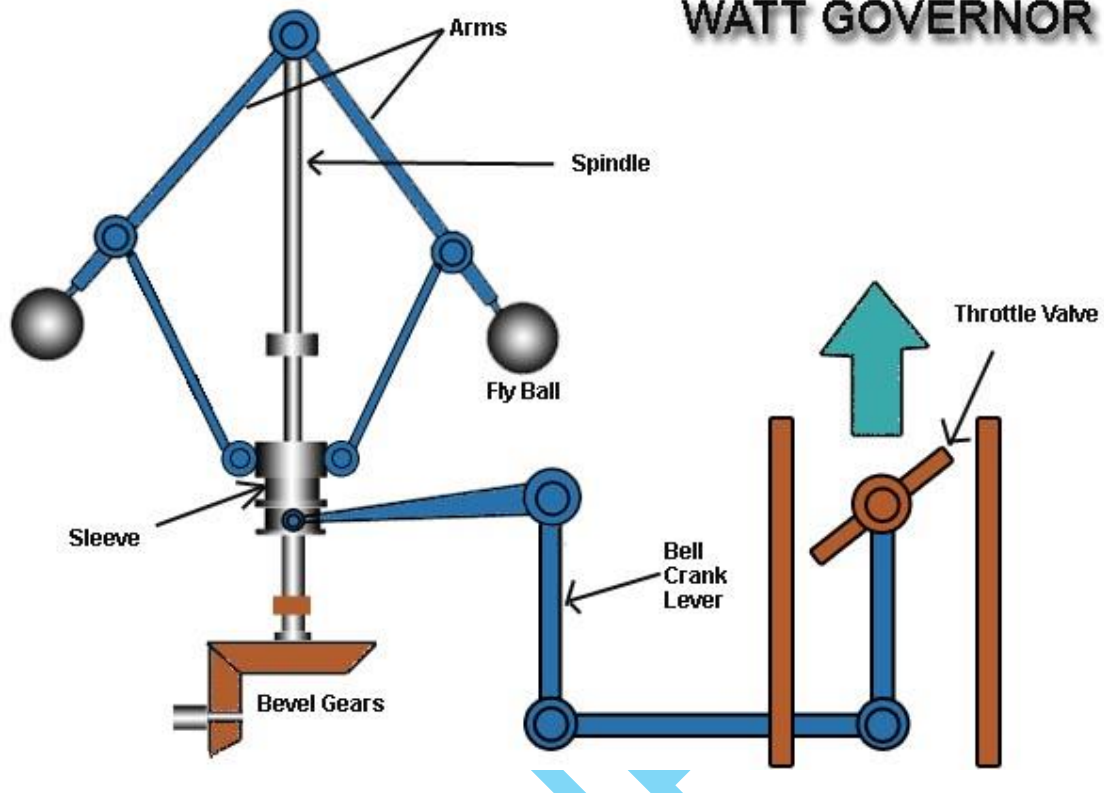

Working of Watt Governor

Watt governors consists of two balls which are attached to both arms which are of negligible mass. The upper side of arms are pivoted so that its balls can move upwards and downwards. These arms are connected to the spindle. The engine drives the spindle through bevel gears.

When the speed of the engine increases, the spindle rotates at high speed. The arms as well as the balls connected to spindle rotates at high speed. As the balls rotates at high speed and the upper side of arms are pivoted to the spindle, the balls moves in upward direction.

The lower arms are connected to the sleeves. These sleeves are keyed to the spindle in such a way that it revolves with the spindle and can slide up and down according to the speed of rotation of spindle.

As the engine speed increases and the balls move in upward direction, the sleeve connected to arms also moves upward and similarly moves downward when the speed of engine decreases. There are stoppers placed above and below the sleeve to limit the upward and downward motion of the sleeve.

Now, there are two cases :-

- i) When engine speed increases.
- ii) When engine speed decreases.

Lets discuss these two case.

i) When the engine speed increases :-

When the speed of engine increases, the load on the engine decreases and the

speed of rotation of spindle increases. The centrifugal force on balls increases and the balls move upwards and hence the sleeve moves upward. As the sleeve moves upward. The upward movement of sleeve causes the throttle valve at the end of the ball crank lever to decrease the fuel supply. The power output is reduced.

ii) When the engine speed decreases:-

When the engine speed decreases, the load on engine increases and speed of rotation of spindle decrease. The centrifugal force on balls decreases and the balls moves downwards. As the balls move downwards, hence the sleeve moves downward which causes the throttle valve to increase the fuel supply and the power output is increased.

Porter Governor:-

1] Porter governor is a type of centrifugal governor with a dead weight attached onto the sleeve.

2] The porter governor is basically invented to overcome the disadvantage of the watt governor since the watt governor is not suitable for high-speed engines. In watt governor, it becomes difficult to adjust the fuel supply at a higher speed.

3] Because of the dead weight attached to the sleeve, the flyball requires more effort to lift the sleeve. hence after attaining the required speed of the engine sleeve starts to slide onto the spindle.

4] Hence the difference because of dead weight between the watt governor and porter governor which causes watt governor is not able to control fuel supply at high speed but porter governor has dead weight which helps to control fuel flow even at high speed.

Diagram

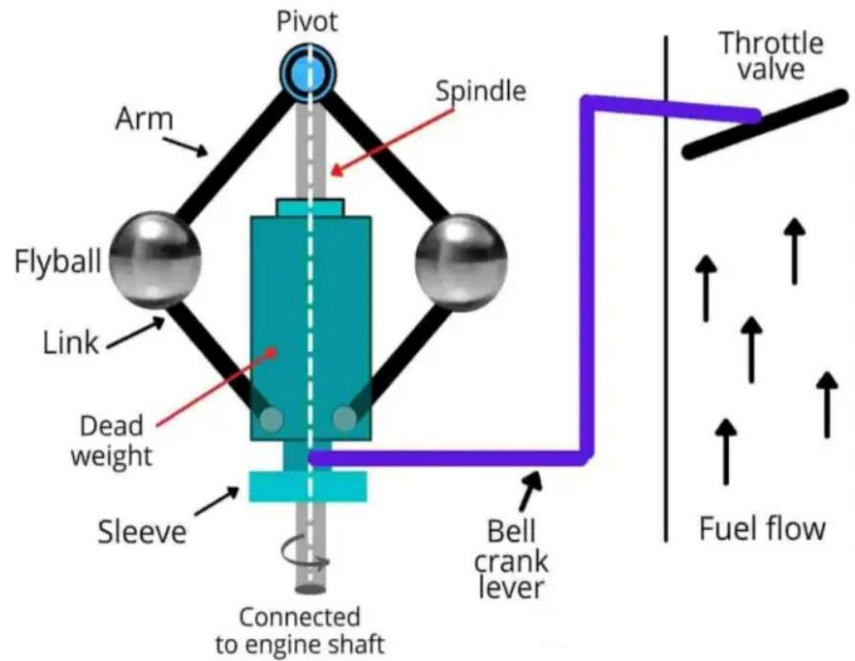

Construction

The porter governor consists of the following components:-

1] Arms & links:- Upper end of the arm is pivoted to the spindle and the lower end is connected to the flyball. One end of the link is connected to flyball & another end of the link is pivoted to the sleeve.

2] Flyballs:- The flyballs are connected between arms & links. The flyballs rotate with the spindle. When the spindle starts to rotate, the flyballs are pushed outward because of [centrifugal force](#) which results in the movement of the sleeve over the spindle of the governor.

3] Dead weight :- This is the main component of this governor which makes it different from other governors.

The deadweight exerts extra force onto the sleeve. Hence sleeve is not easily lifted at lower RPM. Hence when the speed of the engine reaches the desired level the sleeve starts to move onto the spindle.

Working of porter governor:-

Case- I :- When load on engine increases

1] When load on engine increases, the speed of engine decreases.

2] Because of decrease in rotational speed, the centrifugal force on flyballs decreases and flyballs move inwards.

3] Hence radius of rotation of flyballs decreases & sleeve will move in downward direction.

4] This movement of sleeve operates the opening of throttle valve by means of bell crank lever.

5] As the sleeve moves downwards, the opening of the throttle valve increases hence the excess fuel will be supplied to the engine.

Case- I :- When load on engine decreases

1] When the load on engine decreases, the speed of engine increases.

2] Because of increase in rotational speed, the centrifugal force on flyball increases & flyballs are pushed outwards.

3] Hence radius of rotation of flyball increases & sleeve will move in upward direction.

4] As the sleeve moves upwards, the throttle valve opening is decreases and the supply of excess fuel is lowered.

Proell Governor:-

Proell Governor is a different type of governor in which the fly balls are connected to the spindle using an extended arm. The fly balls are mounted on this additional arm. Like the porter governor, proell governor also has central weight which increases the speed of rotation. Proell Governor functions much more accurately than other governors and maintains a constant function without any fluctuation.

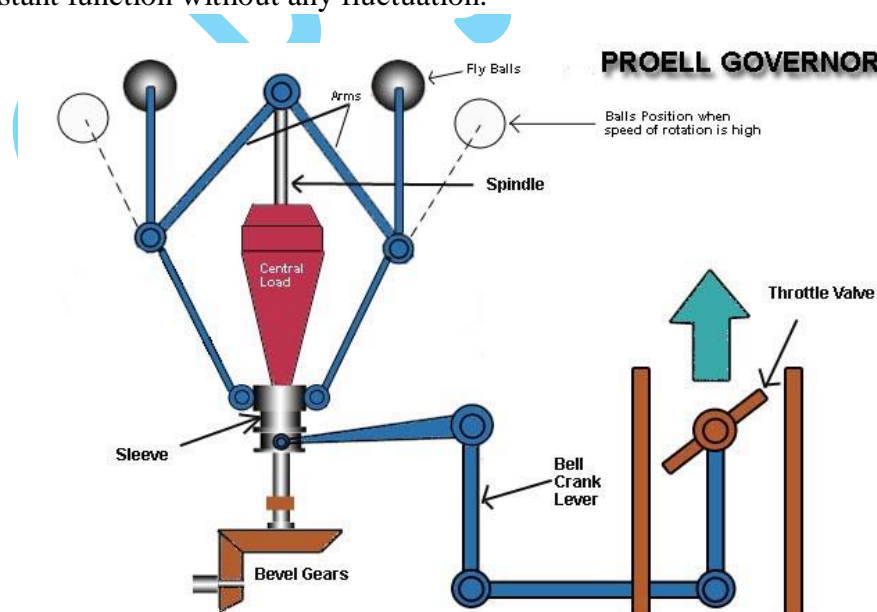

Construction :-

Proell Governor has following parts :- spindle, central weight, arms, extended arms, fly balls and sleeve. The spindle is connected to the engine and its rotation speed increases and decreases with speed of the engine. Spindle has a central load to increase the speed of rotation. Two arms are pivoted at the top of the spindle and these two arms are connected to the extended arms which are connected to the fly balls. The other ends of the two arms which are pivoted to the top of the spindle is connected to the sleeve and moves the sleeve up and down . The sleeve actuates a mechanism which open and close the throttle valve. This sleeve has stoppers in up and bottom to limits its movements.

Working :-

When the load on the engine decreases, the speed of engine increases suddenly and also spindle rotation speed is increased as the spindle is connected to the engine. As the rotation of spindle becomes fast, the arms pivoted to top of spindle also rotates with high speed and the balls move outward due to increased centrifugal force on the balls. When the balls move outward, the sleeve connected to the arms moves up and actuates a mechanism which closes the throttle valve and decreases the fuel supply which decreases the engine speed. Hence the engine speed is maintained.

On the other hand, when the load on the engine increases, speed of the engine decreases. Since the engine speed decreases, speed of rotation of spindle also decreases and hence the ball rotates at low speed and moves inward due to decrease in centrifugal force. As the balls moves inward, the sleeve moves in downward direction which actuates a mechanism which opens the throttle valve and increases the fuels supply and hence the engine speed increases.

In this way speed is maintained by this governor in both the cases.



CHAPTER 2

FLUID MECHANICS

Definition:

A fluid is a substance which is capable of flowing or a substance which deforms continuously when subjected to external shearing force.

Characteristics:

- It has no definite shape of its own but will take the shape of the container in which it is stored.
- A small amount of shear force will cause a deformation.

Classification:

A fluid can be classified as follows:

- Liquid
- Gas

Liquid:

It is a fluid which possesses a definite volume and assumed as incompressible

GAS:

It possesses no definite volume and is compressible.

Fluids are broadly classified into two types.

- Ideal fluids
- Real fluids

Ideal fluid:

An ideal fluid is one which has no viscosity and surface tension and is incompressible actually no ideal fluid exists.

Real fluids:

A real fluid is one which has viscosity, surface tension and compressibility in addition to the density.

PROPERTIES OF FLUIDS:

1. density or mass density : (ρ)

Density of a fluid is defined as the ratio of the mass of a fluid to its volume. It is denoted by ρ .

Mathematically,

$$\rho = \frac{\text{Mass}}{\text{Volume}} = \frac{M}{V}$$

Unit :

In S.I = kg/m^3

In C.G.S = gm/cm^3

The density of water is 1000 kg/m^3 or 1 gm/cm^3

2. Specific weight or weight density (w):

Specific weight of a fluid is defined as the ratio between the weights of a fluid to its volume. It is denoted by w .

$$\text{Mathematically } w = \frac{\text{Weight of the fluid}}{\text{Volume of the fluid}} = \frac{w}{V} = \frac{m \times g}{V}$$

As we know, $w = m \times g$

$$\text{So, } w = \frac{m \times g}{V} = \frac{m}{V} \times g = \rho \times g \quad \left(\frac{m}{V} = \rho \right)$$

Unit:

$$\text{In S.I} = \text{N/m}^3$$

$$\text{In C.G.S} = \text{Dyne/cm}^3$$

3. Specific volume:

Specific volume of a fluid is defined as the volume of a fluid occupied by a unit mass or volume per unit mass of a fluid is called specific volume.

Mathematically,

$$\text{Specific volume} = \frac{\text{Volume}}{\text{Mass}} = \frac{V}{m} = \frac{1}{\frac{m}{V}} = \frac{1}{\rho}$$

Unit :

$$\text{In S.I} = \text{m}^3/\text{kg}$$

$$\text{In C.G.S} = \text{cm}^3/\text{gm}$$

4. Specific gravity (s):

Specific gravity is defined as the ratio of the density (weight density) of a given fluid to the density (weight density) of a standard fluid at standard temperature and pressure.

For liquids the standard fluid is water.

$$\text{Specific gravity, } S = \frac{\text{Density of the given liquid}}{\text{Density of water}} = \frac{\text{Weight density of given liquid}}{\text{Weight of water}}$$

$$\Rightarrow \text{Density of the liquid} = \text{Specific gravity of the liquid} \times \text{Density of water.}$$
$$= S \times 1000 \text{ kg/m}^3$$

$$\Rightarrow \text{Weight density of the liquid} = \text{Specific gravity of the liquid} \times \text{Weight density of water.}$$

$$= S \times 9.81 \times 1000 \text{ N/m}^3$$

5. Viscosity:

Viscosity is defined as the property of a fluid which offers resistance to the movement of one layer of fluid over another adjacent layer of the fluid.

Let two layers of a fluid at a distance dy apart, move one over the other at different velocities u and $u + du$.

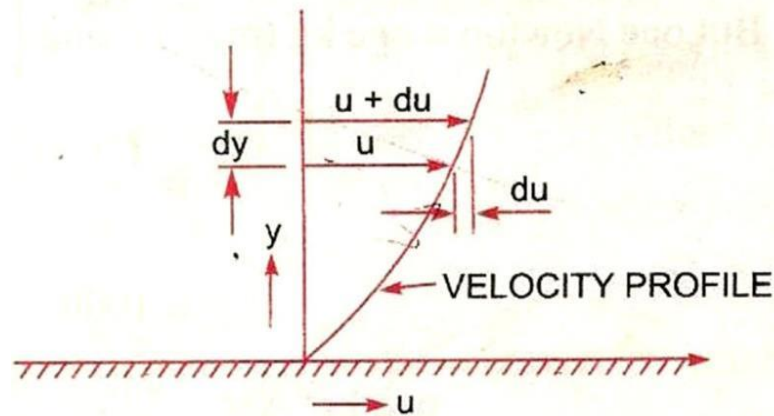

Velocity variation near a solid boundary.

The viscosity together with the relative velocity between the two layers while causes a shear stress acting between the fluid layers, the top layer causes a shear stress on the adjacent lower layer while the lower layer causes a shear stress on the adjacent top layer.

This shear stress is proportional to the rate of change of velocity with respect to y .

It is denoted by τ .

Mathematically

$$\tau \propto \frac{du}{dy}$$

$$\tau = \mu \frac{du}{dy}$$

Where μ = co-efficient of dynamic viscosity or constant of proportionality or viscosity

$\frac{du}{dy}$ = rate of shear strain or velocity gradient.

$$\mu = \frac{\tau}{\frac{du}{dy}}$$

If $\frac{du}{dy} = 1$, then

$$\mu = \tau$$

Viscosity is defined as the shear stress required to produce unit rate of shear strain.

Unit of viscosity

In S.I system

$$\text{N s/m}^2 = 10 \text{ poise}$$

In C.G.S

$$\text{Dyne s/cm}^2 = 1 \text{ poise}$$

In M.K.S

$$\text{Kgf s/m}^2$$

Kinematic Viscosity:

It is defined as the ratio between the dynamic viscosity and density of fluid.

It is denoted by ν (nu).

$$\text{Mathematically, } \nu = \frac{\mu}{\rho}$$

Unit of kinematic viscosity

$$\begin{aligned} \nu &= \frac{\text{Force} \times \text{time}}{\text{length}^2} \times \frac{\text{length}^3}{\text{mass}} = \frac{\text{mass} \times \text{length} \times \text{time}}{\text{time}^2 \times \text{length}^2} \times \frac{\text{length}^3}{\text{mass}} \\ &= \frac{\text{Length}^2}{\text{time}} \end{aligned}$$

In S.I unit = m^2/sec

In C.G.S unit = cm^2/sec

$$1 \text{ cm}^2/\text{s} = 1 \text{ stoke} = 10^{-4} \text{ m}^2/\text{s}$$

Newton's law of viscosity:

It states that the shear stress on a fluid element layer is directly proportional to the rate of shear strain. The constant of proportionality is called the co-efficient of viscosity.

$$\text{Mathematically, } \tau = \mu \frac{du}{dy}$$

Fluids which obey the above equation or law are known as Newtonian fluids & the fluids which do not obey the law are called Non-Newtonian fluids.

6. Surface tension:

Surface tension is defined as the tensile force acting on the surface of a liquid in contact with a gas or on the surface between two immiscible liquids such that the contact surface behaves like a stretched membrane under tension.

The magnitude of this force per unit length of the free surface will have the same value as the surface energy per unit area.

Surface tension on a hollow bubble like soap bubble,

$$p = \frac{8\sigma}{d}$$

Where, p = Pressure intensity inside the droplet.

σ = Surface tension of the liquid.

d = Dia. of droplet.

UNIT:

In S.I – N/m

7. Capillarity:

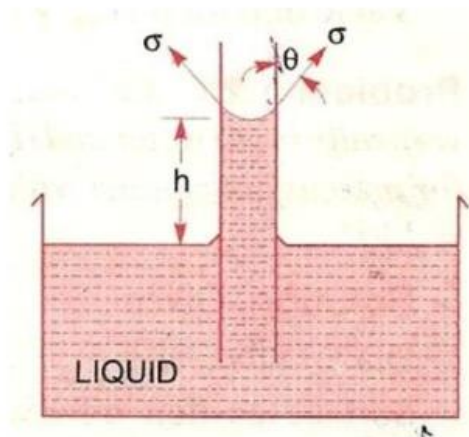

Capillary is defined as a phenomenon of rise or fall of a liquid surface in a small tube relative to the adjacent general level of liquid when the tube is held vertically in the liquid. The rise of liquid surface is known as capillary rise while the fall of the liquid surface is known as capillary depression. It is expressed in terms of cm or mm of liquid. Its value depends on the specific weight of the liquid, diameter of the tube and surface tension of the liquid.

ABSOLUTE, GAUGE, ATMOSPHERIC AND VACCUM PRESSURE:

The pressure on a fluid is measured in two different systems. In one system, it is measured above the absolute zero or complete vacuum and it is called absolute pressure, and in the other system pressure is measured above the atmospheric pressure and it is called as gauge pressure.

1. ABSOLUTE PRESSURE

Absolute pressure is defined as the pressure which is measured with reference to absolute vacuum pressure.

2. GAUGE PRESSURE

It is defined as the pressure which is measured with the help of a pressure measuring instrument, in which the atmospheric pressure is taken as datum. The atmospheric pressure on the scale is marked as zero.

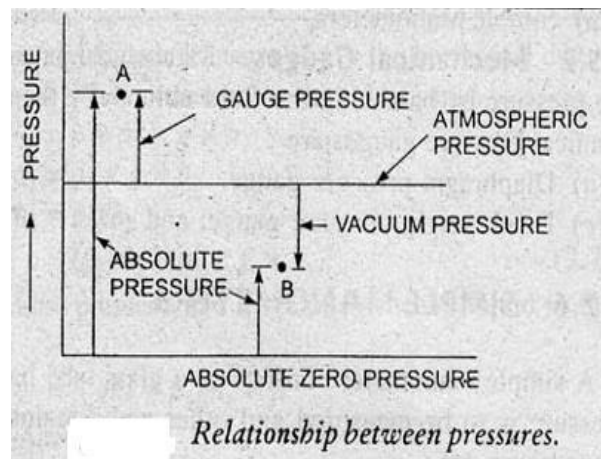

3. VACCUM PRESSURE

It is defined as the pressure below the atmospheric pressure.

- (i) Absolute pressure = $P_{(\text{atmospheric})} + P_{(\text{gauge})}$
 (ii) Vaccum pressure = $P_{(\text{atmospheric})} - P_{(\text{gauge})}$

The atmospheric pressure at sea level at 15°C is 101.3 KN/m^2

In S.I unit = 10.13 N/cm^2

In M.K.S unit = 1.033 Kgf/cm^2

The atmospheric pressure head is 760 mm of Mercury or 10.33 m of water.

PROBLEM:

What are the gauge pressure and absolute pressure at a point 3 m below the free surface of a liquid having a density of $1.53 \times 10^3 \text{ kg/m}^3$, If the atmospheric pressure is equivalent to 750mm of mercury? If the specific gravity of mercury is 13.6 and density of water is 1000 kg/m^3 .

SOLUTION:

Depth of the liquid, $Z_1 = 3\text{m}$

Density of liquid, $\rho_1 = 1.53 \times 10^3 \text{ kg/m}^3$

Atmospheric pressure head, $Z_0 = 750\text{mm of Hg.} = 0.75 \text{ m of Hg.}$

\therefore Atmospheric pressure, $Z_0 = \rho_0 \times g \times Z_0$

$$\begin{aligned} \text{Where } \rho_0 &= \text{Density of Hg} = \text{Specific gravity of Hg} \times \text{Density of water} \\ &= 13.6 \times 1000 = 13600 \text{ kg/m}^3 \end{aligned}$$

And $Z_0 =$ Pressure head in terms of Mercury.

$$\begin{aligned} Z_0 &= 13600 \times 9.81 \times 0.75 \\ &= 100062 \text{ N/m}^2 \end{aligned}$$

Pressure at point, which is at a depth of 3 m from the free surface of the liquid is given by

$$\begin{aligned}P &= \rho_1 \times g \times Z_1 \\ &= (1.53 \times 1000) \times 9.81 \times 3 \\ &= 45028 \text{ N/m}^2\end{aligned}$$

Gauge pressure, $P = 45028 \text{ N/m}^2$

Now absolute pressure = gauge pressure + Atmospheric pressure

$$\begin{aligned}&= 45028 + 100062 \text{ N/m}^2 \\ &= 145090 \text{ N/m}^2\end{aligned}$$

MEASUREMENT OF PRESSURE:

The pressure of a fluid is measured by the following devices:-

1. Manometers
2. Mechanical gauges

1. MANOMETERS:

Manometers are defined as the devices used for measuring the pressure at a point on a fluid by balancing the column of fluid by the same or another column of the fluid. They are classified as

- (a) Simple manometer
- (b) Differential manometer

2. MECHANICAL GAUGES:

Mechanical gauges are defined as the devices used for measuring the pressure by balancing the fluid column by the spring or dead weight.

- e.g. (a) Bourdon tube pressure gauge.
(b) Bellows pressure gauge.
(c) Diaphragm pressure gauge.

SIMPLE MANOMETERS:-

A simple manometer consists of a glass tube having one of its end connected to a point where pressure is to be measured and another end remains open to atmosphere. Common type of simple manometers are:-

1. Piezometer
2. U – tube manometer.
3. Single column manometer.

1. PIEZOMETER:-

It is a simplest form of manometer used for measuring gauge pressure. One end of this manometer is connected to the point where pressure to be measured and other end open to the atmosphere.

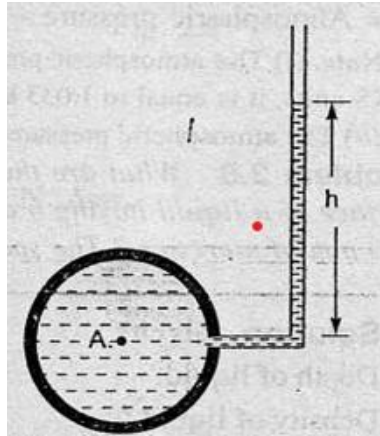

The rise of liquid gives the pressure head at that point. If at a point A, the height of liquid say water is h in piezometer tube, then pressure at A

$$= P + \rho \times g \times h \quad \text{N/m}^2$$

$$= \rho \times g \times h \quad \text{N/m}^2 \quad (\text{Atmospheric pressure, } P = 0)$$

2. U- TUBE MANOMETER :-

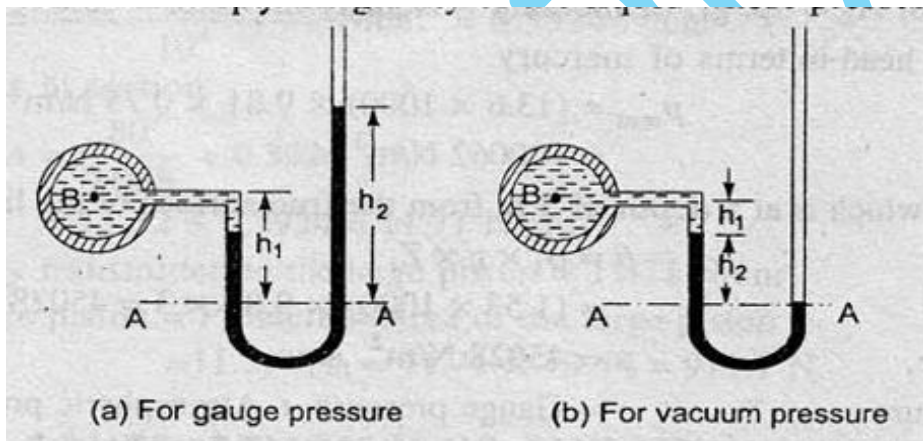

It consists of glass tube bent in U- shape, one end of which is connected to a point at which pressure to be measured and other end remains open to the atmosphere. The tube generally contains Mercury or any other liquid whose specific gravity is greater than the specific gravity of liquid whose pressure is to be measured.

(a) FOR GAUGE PRESSURE :-

Let B is the point at which pressure is to be measured, whose value is 'P'

The datum line is A-A

Let, h_1 = Height of the light liquid above the datum line.

h_2 = Height of the heavy liquid above the datum line.

S_1 = Specific gravity of light liquid.

S_2 = Specific gravity of heavy liquid.

ρ_1 = Density of light liquid = $1000 \times S_1$

ρ_2 = Density of heavy liquid = $1000 \times S_2$

As the pressure is for the horizontal surface, Hence pressure above the horizontal datum line A-A in the left column and in the right column of U-tube manometer should be same.

Pressure above A-A line in the left column

$$= P + \rho_1 \times g \times h_1$$

Pressure above A-A line in the right column

$$= \rho_2 \times g \times h_2$$

Equating the two pressures we get,

$$P + \rho_1 \times g \times h_1 = \rho_2 \times g \times h_2$$

$$\Rightarrow P = (\rho_2 \times g \times h_2) - (\rho_1 \times g \times h_1)$$

(b) FOR VACCUUM PRESSURE :-

Pressure above A-A line in the left column

$$= \rho_2 \times g \times h_2 + P + \rho_1 \times g \times h_1$$

Pressure head in the right column above A-A line = 0

Equating both the pressures we get,

$$\Rightarrow \rho_2 \times g \times h_2 + P + \rho_1 \times g \times h_1 = 0$$

$$\Rightarrow p = - (\rho_2 \times g \times h_2 + \rho_1 \times g \times h_1)$$

PROBLEM

The right limb of a simple U-tube manometer containing Mercury is open to the atmosphere. While the left limb is connected to a pipe in which a fluid of specific gravity 0.9 is flowing. The centre of the pipe is 12 cm below the level of Hg in the right limb. Find the pressure of fluid in the pipe, If the difference in the mercury level in the two limbs is 20 cm.

SOLUTION :-

Specific gravity of fluid $S_1 = 0.9$

Density of fluid, $\rho_1 = S_1 \times 1000 = 0.9 \times 1000 = 900 \text{ Kg/m}^3$

Specific gravity of Mercury, $S_2 = 13.6$

Density of Mercury, $\rho_2 = 13.6 \times 1000 = 13600 \text{ Kg/m}^3$

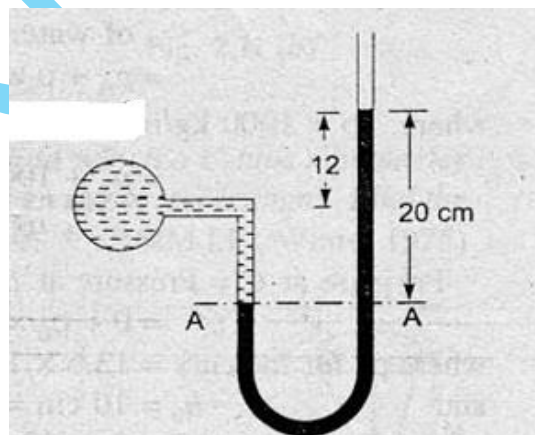

Difference of Mercury level, $h_2 = 20 \text{ cm} = 0.2 \text{ m}$

Height of liquid from A-A level, $h_2 = 20 - 12 = 8 \text{ cm} = 0.08 \text{ m}$

Let, P is the pressure of fluid in pipe

Equating the pressure above A-A we get,

$$P + \rho_1 \times g \times h_1 = \rho_2 \times g \times h_2$$

$$\begin{aligned} \Rightarrow P &= \rho_2 \times g \times h_2 - \rho_1 \times g \times h_1 \\ &= g (\rho_2 \times h_2 - \rho_1 \times h_1) \\ &= 9.81 (13600 \times 0.20 - 900 \times 0.08) \end{aligned}$$

$$\Rightarrow P = 35977 \text{ N/m}^2$$

PROBLEM

A simple U-tube manometer containing mercury is connected to a pipe in which a fluid of specific gravity 0.8 and having vacuum pressure is flowing. The other end of the manometer is open to atmosphere. Find the vacuum pressure in pipe, If the difference of Mercury level in the two limbs is 40 cm and the height of fluid in the left limb from the centre of pipe is 15 cm below.

SOLUTION:

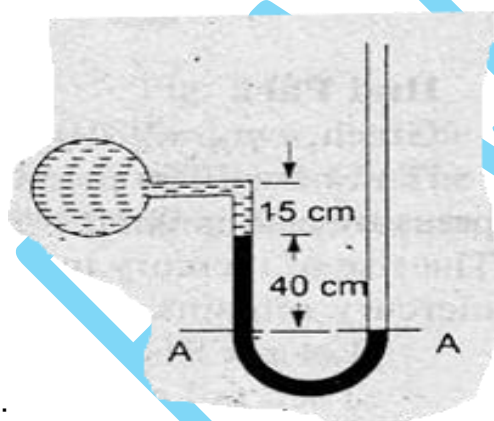

Specific gravity of fluid $S_1 = 0.8$

$$\text{Density of fluid, } \rho_1 = S_1 \times 1000 = 0.8 \times 1000 = 800 \text{ Kg/m}^3$$

Specific gravity of Mercury, $S_2 = 13.6$

$$\text{Density of Mercury, } \rho_2 = 13.6 \times 1000 = 13600 \text{ Kg/m}^3$$

Difference of Mercury level, $h_2 = 40 \text{ cm} = 0.4 \text{ m}$

Height of liquid from A-A level, $h_1 = 15 \text{ cm} = 0.15 \text{ m}$

Let, P is the pressure of fluid in pipe

Equating the pressure above A-A we get,

$$P + \rho_1 \times g \times h_1 + \rho_2 \times g \times h_2 = 0 \quad (\text{Atmospheric pressure on right limb} = 0)$$

$$\begin{aligned} \Rightarrow P &= -(\rho_2 \times g \times h_2 + \rho_1 \times g \times h_1) \\ &= -g(\rho_2 \times h_2 + \rho_1 \times h_1) \\ &= -9.81(13600 \times 0.4 + 800 \times 0.15) \end{aligned}$$

$$\Rightarrow P = -5,454 \text{ N/m}^2$$

CONTINUITY EQUATION

This principle is based on the principle of conservation of mass is called continuity equation. Thus for a fluid flowing through the pipe at all the cross-section, the quantity of fluid flowing per second is constant.

Let V_1, V_2, V_3 = Average velocity at cross-section 1-1, 2-2, 3-3.

ρ_1, ρ_2, ρ_3 = Density of liquid at section 1-1, 2-2, 3-3.

a_1, a_2, a_3 = Area of pipe at section 1-1, 2-2, 3-3.

For steady flow

The quantity of fluid per second is constant at all the cross-section of pipe.

Rate of flow at section 1-1 = 2-2 = 3-3 = constant

$$\Rightarrow \rho_1 a_1 V_1 = \rho_2 a_2 V_2 = \rho_3 a_3 V_3 = \text{constant (For compressible fluid)}$$

For incompressible fluid

$$\rho_1 = \rho_2 = \rho_3 = \rho$$

So continuity equation will be

$$\Rightarrow a_1 V_1 = a_2 V_2 = a_3 V_3 = \text{constant} = Q$$

PROBLEM

The diameter of a pipe at the section 1 and 2 are 10 cm and 15 cm respectively. Find the discharge through the pipe, If the velocity of water flowing through the pipe at section 1 is 5 m/s. Determine also the velocity at section 2.

SOLUTION:**At section 1**

Diameter $d_1 = 10 \text{ cm} = 0.1 \text{ m}$

So area $a_1 = \frac{\pi}{4} (d_1)^2 = \frac{\pi}{4} (0.1)^2 = 0.007854 \text{ m}^2$

And velocity $V_1 = 5 \text{ m/s}$

At section 2

Diameter $d_2 = 15 \text{ cm} = 0.15 \text{ m}$

Area $a_2 = \frac{\pi}{4} (d_2)^2 = \frac{\pi}{4} (0.15)^2 = 0.01767 \text{ m}^2$

(i) Discharge through the pipe is given by
 $Q = a_1 V_1 = 0.00785 \times 5 = 0.03925 \text{ m}^3/\text{s}$

(ii) Using continuity equation

$$a_1 V_1 = a_2 V_2$$
$$0.03925 = 0.01767 \times V_2$$

$$\Rightarrow V_2 = \frac{0.03925}{0.01767}$$

$$\Rightarrow V_2 = 2.222 \text{ m/s}$$

PROBLEM

A 30 cm diameter pipe, conveying water branches into two pipes of diameters 20 cm and 15 cm respectively. If the average velocity in the 30 cm diameter pipe is 2.5 m/s. Find the discharge in this pipe. Also determine the velocity in 15 cm pipe, If the average velocity in 20 cm diameter pipe is 2 m/s.

SOLUTION:**For section 1**

Diameter, $d_1 = 30 \text{ cm} = 0.3 \text{ m}$

So area, $a_1 = \frac{\pi}{4} (d_1)^2 = \frac{\pi}{4} (0.3)^2 = 0.07068 \text{ m}^2$

And velocity, $V_1 = 2.5 \text{ m/s}$

For section 2

Diameter, $d_2 = 20 \text{ cm} = 0.2 \text{ m}$

So area, $a_2 = \frac{\pi}{4} (d_2)^2 = \frac{\pi}{4} (0.2)^2 = 0.03141 \text{ m}^2$

And velocity, $V_2 = 2 \text{ m/s}$

For section 3

Diameter, $d_3 = 15 \text{ cm} = 0.15 \text{ m}$

$$\text{So area, } a_2 = \frac{\pi}{4} (d_1)^2 = \frac{\pi}{4} (0.15)^2 = 0.01767 \text{ m}^2$$

And velocity, $V_3 = ?$

Let Q_1, Q_2, Q_3 are discharges in the pipe through the sections 1, 2 and 3 respectively,

According to continuity equation

$$Q_1 = Q_2 + Q_3$$

$$\Rightarrow a_1 V_1 = a_2 V_2 + a_3 V_3$$

$$\Rightarrow 0.07068 \times 2.5 = 0.03141 \times 2 + 0.01767 \times V_3$$

$$\Rightarrow 0.01767 \times V_3 = 0.07068 \times 2.5 - 0.03141 \times 2$$

$$\Rightarrow V_3 = 6.44 \text{ m/s}$$

RATE OF FLOW OR DISCHARGE :

It is defined as the quantity of fluid flowing per second through any section of a pipe.

Consider a liquid is flowing through a pipe in which,

A = Cross-sectional area of a pipe.

V = Average velocity of liquid across the section

The rate of flow or discharge

$$Q = A \times V$$

The unit of Q is m^3/sec or cm^3/sec .

TYPES OF FLUID FLOW:

(1) Steady and unsteady fluid flow:-

The flow of fluid is said to be steady flow, If the fluid characteristics like – velocity, pressure, density etc. at a point do not change with time, otherwise the flow is known as unsteady flow.

(2) Uniform and non-uniform flow :-

The flow of fluid is said to be uniform, If the velocity of the fluid doesn't change at any given time at any section of the pipe, Otherwise the flow of fluid is known as non-uniform flow.

(3) Compressible and incompressible flow :-

The flow of fluid is said to be compressible, If the density of the fluid changes from point to point, otherwise known as incompressible flow.

(4) Rotational and irrotational flow :-

Rotational flow is that type of fluid flow in which the fluid particles while flowing along streamlines also rotate about their own axis, otherwise the flow is known as irrotational flow.

(5) Laminar flow :-

Laminar fluid flow is that type of fluid flow in which fluid particles are move along a well defined path and all streamlines are straight and parallel.

(6) Turbulent flow :-

Turbulent fluid flow is that type of fluid flow in which fluid particles move in a zigzag path.

BERNOULLI'S EQUATION FROM EULER'S EQUATION

Euler's equation is

$$\frac{dP}{\rho} + g dz + v \cdot dv = 0$$

By integrating Euler's equation we can get Bernoulli's equation

$$\text{So } \int \frac{dP}{\rho} + \int g \cdot dz + \int v \cdot dv = 0$$

As g is constant and for incompressible flow ρ is constant

So the above equation will be

$$\frac{1}{\rho} \int dp + g \int dz + \int v \cdot dv = 0$$

$$\Rightarrow \frac{P}{\rho} + gz + \frac{v^2}{2} = \text{constant}$$

Dividing g on both sides we get

$$\frac{P}{\rho g} + \frac{gz}{g} + \frac{v^2}{2g} = \text{constant}$$

$$\Rightarrow \frac{P}{\rho g} + \frac{v^2}{2g} + z = \text{constant}$$

Here, $\frac{P}{\rho g}$ is known as pressure head

$\frac{v^2}{2g}$ is known as velocity head / kinetic head

And z is known as Datum head

STATEMENT OF BERNOULLI'S EQUATION

This equation states that in a steady, incompressible and ideal fluid flow, the total energy of the fluid (pressure, kinetic and datum) is always constant.

ASSUMPTIONS FOR BERNOULLI'S EQUATION

→ Fluid is ideal i.e viscosity is zero.

→ The flow is steady.

→ The flow is incompressible.

→ The flow is irrotational.

PROBLEM

Water is flowing through a pipe having diameter 20 cm and 10 cm at section 1 and section 2 respectively. The rate of flow through pipe is 35 lit./s. Section- 1 is 6 m above datum and section- 2 is 4 m above datum. If the pressure in section- 1 is 39.24 N/cm². Find the intensity of pressure at section- 2 ?

SOLUTION

Given data

$$\text{Rate of flow, } Q = 35 \text{ lit./s} = \frac{35}{1000} \text{ m}^3/\text{s} = 0.035 \text{ m}^3/\text{s}$$

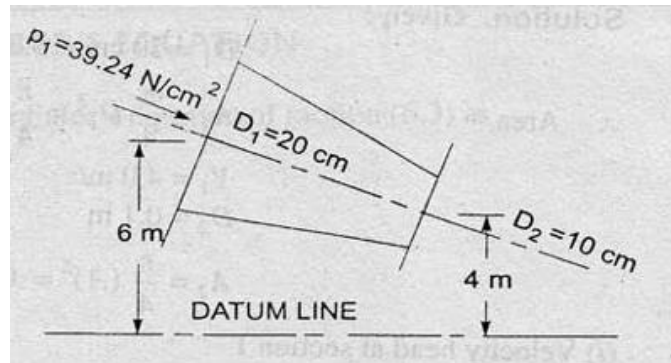

For section 1

Diameter, $d_1 = 20 \text{ cm} = 0.2 \text{ m}$

$$\text{So area, } a_1 = \frac{\pi}{4} (d_1)^2 = \frac{\pi}{4} (0.2)^2 = 0.03141 \text{ m}^2$$

Pressure intensity, $P_1 = 39.24 \text{ N/cm}^2 = 39.24 \times 10^4 \text{ N/m}^2$

And datum head, $Z_1 = 6 \text{ m}$

For section 2

Diameter, $d_2 = 10 \text{ cm} = 0.1 \text{ m}$

$$\text{So area, } a_2 = \frac{\pi}{4} (d_2)^2 = \frac{\pi}{4} (0.1)^2 = 0.00785 \text{ m}^2$$

Pressure intensity, $P_2 = ?$

And datum head, $Z_2 = 4 \text{ m}$

We know that Discharge, $Q = a_1 V_1 = a_2 V_2$

$$\Rightarrow V_1 = \frac{Q}{a_1} = \frac{0.035}{0.03141} = 1.114 \text{ m/s}$$

$$\text{And, } V_2 = \frac{Q}{a_2} = \frac{0.035}{0.00785} = 4.458 \text{ m/s}$$

Applying Bernoulli's equation we get,

$$\frac{P_1}{\rho g} + \frac{v_1^2}{2g} + Z_1 = \frac{P_2}{\rho g} + \frac{v_2^2}{2g} + Z_2$$

$$\Rightarrow \frac{39.24 \times 10^4}{1000 \times 9.81} + \frac{(1.114)^2}{2 \times 9.81} + 6 = \frac{P^2}{1000 \times 9.81} + \frac{(4.458)^2}{2 \times 9.81} + 4$$

$$\Rightarrow 40 + 0.0632 + 2 = \frac{P^2}{9810} + 1.0129$$

$$\Rightarrow \frac{P^2}{9810} = 41.0503$$

$$\Rightarrow P^2 = 402703.443 \text{ N/m}^2 = 40.27 \times 10^4 \text{ N/m}^2$$

PROBLEM

A pipe of diameter 400 mm carries water at a velocity of 25 m/s, the pressure at point A and B are given as 29.43 N/cm² and 22.563 N/cm² respectively. While the datum head at A and B are 28 m and 30 m. Find the loss of head at A and B.

SOLUTION:

Given data

Diameter, $d = 400 \text{ mm}$

Velocity, $V = 25 \text{ m/s}$

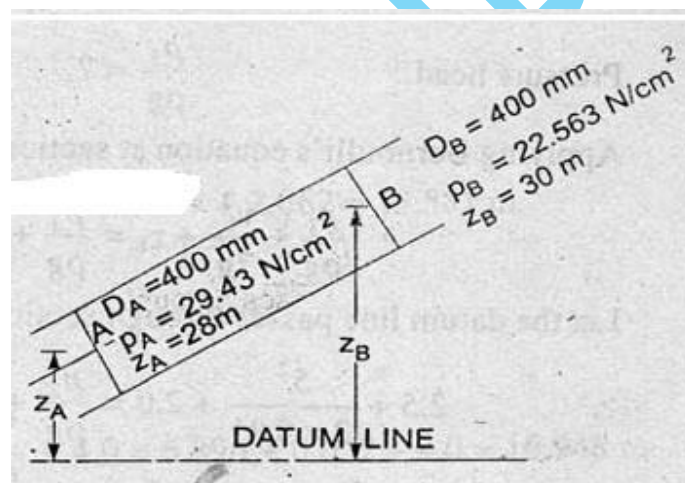

At point A

Pressure at point A, $P_A = 29.43 \text{ N/cm}^2 = 29.43 \times 10^4 \text{ N/m}^2$

Datum head at point A, $Z_A = 28 \text{ m}$

Velocity at point A, $V_A = V = 25 \text{ m/s}$

∴ Total energy/ Head at point A

$$E_A = \frac{P_A}{\rho g} + \frac{v_A^2}{2g} + z_A$$

$$= \frac{29.43 \times 10^4}{1000 \times 9.81} + \frac{(25)^2}{2 \times 9.81} + 28$$

$$= 30 + 31.855 + 28$$

$$= 89.855 \text{ m}$$

At point B

Pressure at point A, $P_B = 22.563 \text{ N/cm}^2 = 22.563 \times 10^4 \text{ N/m}^2$

Datum head at point A, $Z_B = 30 \text{ m}$

Velocity at point A, $V_A = V = 25 \text{ m/s}$

∴ Total energy/ Head at point B

$$E_B = \frac{P_B}{\rho g} + \frac{v_B^2}{2g} + z_B$$

$$E_B = \frac{22.563 \times 10^4}{1000 \times 9.81} + \frac{(25)^2}{2 \times 9.81} + 30$$

$$= 23 + 31.855 + 30$$

$$= 84.855 \text{ m}$$

Loss of energy/ head = $P_A - P_B = 89.855 - 84.855 = 5 \text{ m}$

PROBLEM

Water is flowing through a pipe having diameter 300 mm and 200 mm at the bottom and upper end respectively. The intensity of pressure at the bottom end is 24.525 N/cm² and the pressure at the upper end is 9.81 N/cm². Determine the difference in datum head, If the rate of flow through pipe is 40 lit./s.

SOLUTION

Given data

Rate of flow / Discharge, $Q = 40 \text{ lit./sec}$

$$= \frac{40}{1000} = 0.04 \text{ m}^3/\text{s}$$

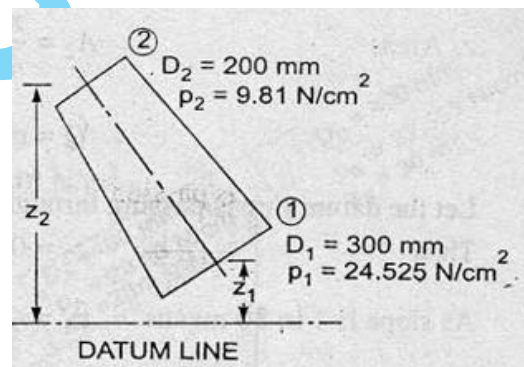

For section 1

Diameter of pipe, $d_1 = 300 \text{ mm} = 0.3 \text{ m}$

$$\text{Area of the pipe } a_1 = \frac{\pi}{4} (d_1)^2 = \frac{\pi}{4} (0.3)^2 = 0.0706 \text{ m}^2$$

$$\text{Pressure, } P_1 = 24.525 \text{ N/cm}^2 = 24.525 \times 10^4 \text{ N/m}^2$$

From continuity equation we know that,

$$Q = a_1 v_1$$

$$\Rightarrow v_1 = \frac{Q}{a_1} = \frac{0.04}{0.0706} = 0.5665 \text{ m/s}$$

For section 2

Diameter of pipe, $d_2 = 200 \text{ mm} = 0.2 \text{ m}$

$$\text{Area of the pipe } a_2 = \frac{\pi}{4} (d_2)^2 = \frac{\pi}{4} (0.2)^2 = 0.0314 \text{ m}^2$$

$$\text{Pressure, } P_2 = 9.81 \text{ N/cm}^2 = 9.81 \times 10^4 \text{ N/m}^2$$

From continuity equation we know that,

$$Q = a_2 v_2$$

$$\Rightarrow v_2 = \frac{Q}{a_2} = \frac{0.04}{0.0314} = 1.2738 \text{ m/s}$$

Now applying Bernoulli's equation at section - 1 and section - 2 we get,

$$\begin{aligned} \Rightarrow \frac{P_1}{\rho g} + \frac{v_1^2}{2g} + Z_1 &= \frac{P_2}{\rho g} + \frac{v_2^2}{2g} + Z_2 \\ \Rightarrow Z_1 - Z_2 &= \frac{P_2}{\rho g} + \frac{v_2^2}{2g} - \left(\frac{P_1}{\rho g} + \frac{v_1^2}{2g} \right) \\ &= \frac{P_2}{\rho g} - \frac{P_1}{\rho g} + \frac{v_2^2}{2g} - \frac{v_1^2}{2g} \\ &= \left(\frac{9.81 \times 10^4}{1000 \times 9.81} - \frac{24.525 \times 10^4}{1000 \times 9.81} \right) + \left(\frac{(1.2738)^2}{2 \times 9.81} - \frac{(0.5665)^2}{2 \times 9.81} \right) \\ \Rightarrow Z_1 - Z_2 &= 14.9337 \text{ m} \end{aligned}$$

Practical application of Bernoulli's equation

Bernoulli's equation is applied in all problems of incompressible fluid flow where energy considerations are involved. But we shall consider its application to the following measuring devices :

1. Venturimeter.
2. Orifice meter.
3. Pitot-tube.

VENTURIMETER :-

It is a device, used for measuring the rate of flow of fluid flowing through a pipe.

It consists of three parts

- (i) Convergent
- (ii) Divergent and
- (iii) Throat.

It based on the principle of Bernoulli's equation

Expression for rate of flow through venturi meter :

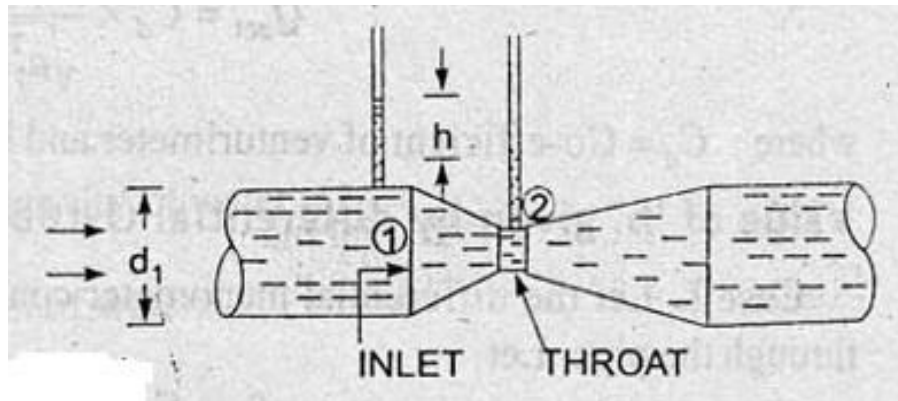

Consider a venturimeter fitted in a horizontal pipe through which a fluid is flowing,

Let,

d_1 = Diameter at inlet or section -1

P_1 = Pressure at section -1

V_1 = Velocity of fluid at section -1

A_1 = area at section -1 = $\frac{\pi}{4} (d_1)^2$

And d_2, P_2, V_2, a_2 are corresponding values at section -2

Applying Bernoulli's equation for section -1 and -2 we get,

$$\frac{P^1}{\rho g} + \frac{v^{12}}{2g} + Z_1 = \frac{P^2}{\rho g} + \frac{v^{22}}{2g} + Z_2$$

As pipe is horizontal, hence $z_1 = z_2$

$$\text{So, } \frac{P^1}{\rho g} + \frac{v^{12}}{2g} = \frac{P^2}{\rho g} + \frac{v^{22}}{2g}$$

$$\Rightarrow \frac{P^1}{\rho g} - \frac{P^2}{\rho g} = \frac{v^{22}}{2g} - \frac{v^{12}}{2g}$$

$$\Rightarrow \frac{P^1 - P^2}{\rho g} = \frac{v^{22}}{2g} - \frac{v^{12}}{2g}$$

But, $\frac{P^1 - P^2}{\rho g}$ is the difference of pressure head at section -1 and -2 and is equal to h.

$$\Rightarrow \frac{P^1 - P^2}{\rho g} = h$$

Substituting the value of $\frac{P^1 - P^2}{\rho g}$ in the above equation we get,

$$\Rightarrow h = \frac{v_2^2}{2g} - \frac{v_1^2}{2g}$$

Now applying continuity equation for section -1 and -2 we get

$$a_1 V_1 = a_2 V_2$$

$$\Rightarrow V_1 = \frac{a_2 V_2}{a_1}$$

Substituting the value of V_1 on above equation we get,

$$\begin{aligned} h &= \frac{v_2^2}{2g} - \frac{\left(\frac{a_2 V_2}{a_1}\right)^2}{2g} \\ &= \frac{v_2^2}{2g} - \frac{a_2^2 V_2^2}{a_1^2 2g} \\ &= \frac{v_2^2}{2g} \left(\frac{a_1^2 - a_2^2}{a_1^2}\right) \end{aligned}$$

$$\Rightarrow V_2^2 = 2gh \times \frac{a_1^2}{a_1^2 - a_2^2}$$

$$\Rightarrow V_2 = \sqrt{2gh \times \frac{a_1^2}{a_1^2 - a_2^2}} = \sqrt{2gh} \times \sqrt{\frac{a_1^2}{a_1^2 - a_2^2}}$$

$$\Rightarrow V_2 = \frac{a_1}{\sqrt{a_1^2 - a_2^2}} \times \sqrt{2gh}$$

As Discharge, $Q = a_2 V_2$

$$\text{So, } Q = a_2 \times \frac{a_1}{\sqrt{a_1^2 - a_2^2}} \times \sqrt{2gh}$$

$$\Rightarrow Q = \frac{a_1 \times a_2}{\sqrt{a_1^2 - a_2^2}} \times \sqrt{2gh}$$

This gives the discharge under ideal conditions and is called theoretical discharge. The actual discharge will be less than that of theoretical discharge.

$$Q_{\text{act.}} = C_d \times Q_{\text{th.}} = C_d \times \frac{a_1 \times a_2}{\sqrt{a_1^2 - a_2^2}} \times \sqrt{2gh}$$

Where C_d is called co-efficient of discharge for venturimeter and it is always less than 1 and the value of h is given by differential U-tube manometer.

Case I

Let the differential manometer contained a liquid which is heavier than the liquid flowing through the pipe.

Let,

S_h = Specific gravity of heavier liquid.

S_o = Specific gravity of the liquid flowing through the pipe.

x = Difference of the heavier liquid column in U-tube manometer.

Then,
$$h = x \left(\frac{S_h}{S_o} - 1 \right)$$

Case II

If the differential manometer contains a liquid which is lighter than the liquid flowing through the pipe, the value of "h" is given by

$$h = x \left(1 - \frac{S_1}{S_o} \right)$$

Where,

S_1 = Specific gravity of lighter liquid in U-tube manometer.

S_o = Specific gravity of liquid flowing through the pipe.

x = Difference of the lighter liquid column in U-tube manometer.

Case III

INCLINED VENTURIMETER WITH U-TUBE MANOMETER

Let the differential manometer contains heavier liquid than the liquid than the liquid flowing through the venturimeter, then 'h' is given by

$$h = \left(\frac{P_1}{\rho g} + Z_1 \right) - \left(\frac{P_2}{\rho g} + Z_2 \right) = x \left(\frac{S_h}{S_o} - 1 \right)$$

Case IV

Similarly for inclined venturimeter in which differential manometer contains a liquid which is lighter than the liquid flowing through the pipe, the value of 'h' is given by

$$h = \left(\frac{P_1}{\rho g} + Z_1 \right) - \left(\frac{P_2}{\rho g} + Z_2 \right) = x \left(1 - \frac{S_1}{S_o} \right)$$

PROBLEM

A horizontal venturimeter with inlet and throat diameters 30 cm and 15 cm respectively is used to measure the flow of water. The reading of differential manometer connected to the inlet and throat is 20 cm of mercury. Determine the rate of flow. Take $C_d = 0.98$

SOLUTION

Given data

Dia. of inlet, $d_1 = 30$ cm.

$$\therefore \text{Area of inlet, } a_1 = \frac{\pi}{4} (d_1)^2 = \frac{\pi}{4} (30)^2 = 706.85 \text{ cm}^2$$

Dia. of throat, $d_2 = 15$ cm.

$$\therefore \text{Area of throat, } a_2 = \frac{\pi}{4} (d_2)^2 = \frac{\pi}{4} (15)^2 = 176.7 \text{ cm}^2$$

And $C_d = 0.98$

Reading of differential manometer, $x = 20$ cm of Hg.

Differential pressure head is given by

$$h = x \left(\frac{S_h}{S_o} - 1 \right)$$

Where, $S_h =$ specific gravity of mercury = 13.6

$S_o =$ Specific gravity of water = 1

$$\therefore h = 20 \times \left(\frac{13.6}{1} - 1 \right) = 20 \times 12.6 = 252 \text{ cm of water.}$$

Discharge through venturimeter is given by

$$Q_{act.} = C_d \times \frac{a_1 \times a_2}{\sqrt{a_1^2 - a_2^2}} \times \sqrt{2gh} = 0.98 \times \frac{706.85 \times 176.7}{\sqrt{(706.85)^2 - (176.7)^2}} \times \sqrt{2 \times 9.81 \times 252}$$

$$Q_{act.} = \frac{86067593.36}{684.4} = 125756 \text{ cm}^3/\text{sec}$$

$$Q_{act.} = \frac{125756}{1000} \text{ lit./s}$$

$$Q_{act.} = 125.756 \text{ lit./s}$$

PROBLEM

An oil of specific gravity 0.8 is flowing through a venturimeter having inlet dia. 20 cm and throat dia. 10 cm. The oil mercury differential manometer shows a reading of 25 cm. Calculate the discharge of oil through the horizontal venturimeter. Take $C_d = 0.98$.

SOLUTION:

Given data,

Specific gravity of oil, $S_o = 0.8$

Specific gravity of mercury = 13.6

Reading of differential manometer, $x = 25$ cm

$$\text{Differential of pressure head, } h = x \left(\frac{S_1}{S_0} - 1 \right) = 25 \times \left(\frac{13.6}{0.8} - 1 \right)$$

$$= 25 \times (17-1)$$

$$\Rightarrow h = 400 \text{ cm of oil.}$$

Dia. of inlet, $d_1 = 20 \text{ cm.}$

$$\therefore \text{Area of inlet, } a_1 = \frac{\pi}{4} (d_1)^2 = \frac{\pi}{4} (20)^2 = 314.16 \text{ cm}^2$$

Dia. of throat, $d_2 = 10 \text{ cm.}$

$$\therefore \text{Area of throat, } a_2 = \frac{\pi}{4} (d_2)^2 = \frac{\pi}{4} (10)^2 = 78.54 \text{ cm}^2$$

And $C_d = 0.98$

Discharge, Q is given by the equation

$$Q_{\text{act.}} = C_d \times \frac{a_1 \times a_2}{\sqrt{a_1^2 - a_2^2}} \times \sqrt{2gh} = 0.98 \times \frac{314.16 \times 78.54}{\sqrt{(314.16)^2 - (78.54)^2}} \times \sqrt{2 \times 9.81 \times 400}$$

$$Q_{\text{act.}} = 70465 \text{ cm}^3/\text{sec}$$

$$Q_{\text{act.}} = \frac{70465}{1000} \text{ lit./s}$$

$$Q_{\text{act.}} = 70.465 \text{ lit./s}$$

PROBLEM

A horizontal venturimeter with inlet diameter 20 cm and throat diameter 10 cm is used to measure the flow of oil of specific gravity 0.8. The discharge of oil through venturimeter is 60 lit./s. Find the oil-mercury differential manometer. Take $C_d = 0.98$

PROBLEM

A horizontal venturimeter with inlet diameter 20 cm and throat diameter 10 cm is used to measure the flow of water. The pressure at inlet is 17.658 N/cm² and the vacuum pressure at the throat is 30 cm of Mercury. Find the discharge of water through venturimeter. Take $C_d = 0.98$

SOLUTION:

Given data

Dia. of inlet, $d_1 = 20 \text{ cm.}$

$$\therefore \text{Area of inlet, } a_1 = \frac{\pi}{4} (d_1)^2 = \frac{\pi}{4} (20)^2 = 314.16 \text{ cm}^2$$

Dia. of throat, $d_2 = 10 \text{ cm.}$

$$\therefore \text{Area of throat, } a_2 = \frac{\pi}{4} (d_2)^2 = \frac{\pi}{4} (10)^2 = 78.54 \text{ cm}^2$$

And $C_d = 0.98$

Pressure at inlet, $P_1 = 17.658 \text{ N/cm}^2 = 17.658 \times 10^4 \text{ N/m}^2$

Density of water 1000 Kg/m^3

Pressure at throat, $x = -30 \text{ cm of mercury} = \frac{30}{100} = -0.3 \text{ m of mercury.}$

As we know $P_1 = \rho g h_1$

$$\text{So, } \frac{P_1}{\rho g} = \frac{17.658 \times 10^4}{9.81 \times 1000} = 18 \text{ m of water.}$$

Similarly, $\frac{P_2}{\rho g} = h_2 \text{ of mercury} \times \text{Specific gravity of mercury}$

$$= -0.3 \times 13.6 = -4.08 \text{ m of water}$$

So, differential pressure head,

$$h = \frac{P_1}{\rho g} - \frac{P_2}{\rho g} = 18 - (-4.08) = 22.08 \text{ m of water} = 2208 \text{ cm of water}$$

The discharge Q is given by the equation

$$\begin{aligned} Q_{\text{act.}} &= C_d \times \frac{a_1 \times a_2}{\sqrt{a_1^2 - a_2^2}} \times \sqrt{2gh} = 0.98 \times \frac{314.16 \times 78.54}{\sqrt{(314.16)^2 - (78.54)^2}} \times \sqrt{2 \times 9.81 \times 2208} \\ &= \frac{50328837.21}{304} \times 165555 \text{ cm}^3/\text{s} \\ &= 165.555 \text{ lit./s} \end{aligned}$$

PROBLEM

The inlet and throat diameters of a horizontal venturimeter are 30 cm and 10 cm respectively. The liquid flowing through the meter is water. The pressure intensity at inlet is 13.734 N/cm^2 , while the vacuum pressure head at the throat is 37 cm of Hg. Find the rate of flow. Assume that 4% of the differential head is lost between the inlet and throat. Find also the value of C_d for the venturimeter.

SOLUTION:

Given data

Dia. of inlet, $d_1 = 30 \text{ cm.}$

$$\therefore \text{Area of inlet, } a_1 = \frac{\pi}{4} (d_1)^2 = \frac{\pi}{4} (30)^2 = 706.85 \text{ cm}^2$$

Dia. of throat, $d_2 = 10 \text{ cm.}$

$$\therefore \text{Area of throat, } a_2 = \frac{\pi}{4} (d_2)^2 = \frac{\pi}{4} (10)^2 = 78.54 \text{ cm}^2$$

And $C_d = 0.98$

Pressure at inlet, $P_1 = 13.734 \text{ N/cm}^2 = 13.734 \times 10^4 \text{ N/m}^2$

Pressure head $\frac{P_1}{\rho g} = \frac{13.734 \times 10^4}{9.81 \times 1000} = 14 \text{ m of water.}$

$$\frac{P_2}{\rho g} = -37 \text{ cm of Hg}$$

$$= -37 \times 13.6 \text{ cm of water}$$

$$= -\frac{503.2}{100} = -5.032 \text{ m of water}$$

Differential head $h = \frac{P_1}{\rho g} - \frac{P_2}{\rho g} = 14 - (-5.032) = 19.032 \text{ m of water}$

= 1903.2 cm of water

Head loss $h_f = 4\% \text{ of } h = 19.032 \times \frac{4}{100} = 0.7613 \text{ m of water}$

We know that $C_d = \sqrt{\frac{h-h_f}{h}} = \sqrt{\frac{19.032-0.7613}{19.032}} = 0.98$

Discharge through a venturimeter, $Q =$

$$C_d \times \frac{a^1 \times a^2}{\sqrt{a^{12} - a^{22}}} \times \sqrt{2gh} = 0.98 \times \frac{706.85 \times 78.54}{\sqrt{(706.85)^2 - (78.54)^2}} \times \sqrt{2 \times 9.81 \times 1903.2}$$

$$= 149692.8 \text{ cm}^3/\text{s} = 0.1496928 \text{ m}^3/\text{s}$$

ORIFICES

It is a small opening of any cross-section such as – circular, triangular, rectangular on the side or at the bottom of a tank through which a fluid is flowing.

A mouth piece is a short length of a pipe which is two or three times of its diameter in length fitted in a tank.

Both orifice and mouth piece are used to measure rate of flow,

CLASSIFICATION OF ORIFICE:-

(i) Small orifice and large orifice:-

- If the head of liquid from the centre of orifice is more than five times the depth of orifice, is called small orifice.
- If the head of the liquid from the centre of orifice is less than five times the depth of orifice, the orifice is called as large orifice.

(ii) According to cross-section:-

- Circular.
- Triangular.
- Rectangular.
- Square etc.

(iii) According to shape of edge:-

- Sharp edge.
- Bell mounted.

(iv) **According to nature of discharge:-**

- Free discharge orifice.
- Drowned / Submerged orifice.

(v) **Submerged orifice:-**

- Fully submerged.
- Partially submerged.

FLOW THROUGH AN ORIFICE:-

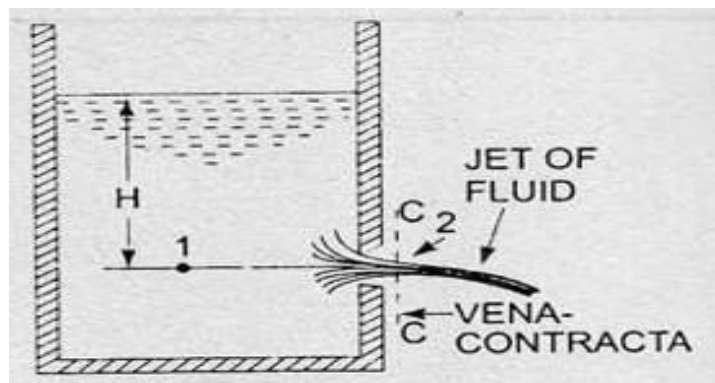

Consider a tank fitted with a circular orifice in one of its sides. Let H be the head of the liquid above the centre of the orifice. The liquid flowing through the orifice forms a jet of liquid whose area of cross-section is less than that of orifice, The area of jet of liquid goes on decreasing and a section C-C, the area is minimum. This section is approximately at a distance of half of diameter of the orifice. At this section, the streamlines are straight and parallel to each other and perpendicular to the plane of orifice. This section is called vena-contracta. Beyond this section, the jet diverges and is attracted in the downward direction by the gravity.

Consider two points 1 and 2. The point 1 is inside the tank and the point 2 is at the vena-contracta. Let the flow is steady and at a constant head H .

Applying Bernoulli's theorem at point 1 and 2 we get.

$$\frac{P_1}{\rho g} + \frac{v_1^2}{2g} + Z_1 = \frac{P_2}{\rho g} + \frac{v_2^2}{2g} + Z_2$$

As $z_1 = z_2$, then the above equation will be

$$\Rightarrow \frac{P_1}{\rho g} + \frac{v_1^2}{2g} + Z_1 = \frac{P_2}{\rho g} + \frac{v_2^2}{2g} + Z_2$$

$$\text{As } \frac{P_1}{\rho g} = H, \quad \text{and} \quad \frac{P_2}{\rho g} = 0 \quad (\text{Atmospheric pressure} = 0)$$

As V_1 is very small in comparison to V_2 as area of tank is very large as compared to area of jet of liquid.

$$\therefore H + 0 = 0 + \frac{v_2^2}{2g}$$

$$\Rightarrow V_2^2 = 2gH$$

$$\Rightarrow V_2 = \sqrt{2gH}$$

This is theoretical velocity and the actual velocity is less than that of this value.

HYDRAULIC CO-EFFICIENTS

The hydraulic co-efficients are

1. Co-efficient of velocity (C_v)
2. Co-efficient of contraction (C_c)
3. Co-efficient of discharge (C_d)

1. Co-efficient of velocity (C_v):-

It is defined as the ratio between the actual velocity of a jet of liquid at vena-contracta to the theoretical velocity of the jet.

It is denoted by C_v , and mathematically

$$C_v = \frac{\text{Actual velocity of jet at vena-contracta}}{\text{Theoretical velocity of the jet}}$$

$$\Rightarrow C_v = \frac{V}{\sqrt{2gH}}$$

Where, V = Actual velocity of the jet.

And $\sqrt{2gH}$ = Theoretical velocity of the jet at vena-contracta.

The value of C_v varies from 0.95 to 0.99 for different orifices, depending upon the shape, size of the orifice and on the head under which flow takes place. Generally the value of $C_v = 0.98$ is taken for sharp edged orifice.

2. Co-efficient of contraction (C_c):-

It is defined as the ratio of the area of the jet at vena-contracta to the area of the orifice. It is denoted by C_c .

Let, a = area of orifice

And a_c = area of jet at venacontracta.

$$C_c = \frac{\text{Area of jet at venacontracta}}{\text{Area of orifice}}$$

$$C_c = \frac{a_c}{a}$$

The value of C_c varies from 0.61 to 0.69 depending on shape and size of the orifice and head of liquid under which flow takes place. In general value of C_c may be taken as 0.64.

3. Co-efficient of discharge (C_d):-

It is defined as the ratio of the actual discharge from an orifice to the theoretical discharge discharge from the orifice.

It is denoted by C_d . If Q is actual discharge and Q_{th} is theoretical discharge then mathematically,

$$C_d = \frac{Q}{Q_{th}} = \frac{\text{Actual velocity} \times \text{Actual area}}{\text{Theoretical velocity} \times \text{Theoretical area}}$$

$$= \frac{\text{Actual velocity}}{\text{Theoretical velocity}} \times \frac{\text{Actual area}}{\text{Theoretical area}}$$

$$\Rightarrow C_d = C_v \times C_c$$

The value of C_d varies from 0.61 to 0.65 for general purpose, the value of C_d is taken as 0.62.

PROBLEM

The head of water over an orifice of diameter 40 mm is 10 m. Find actual discharge and actual velocity of the jet at venacontracta. Take $C_d = 0.6$ and $C_v = 0.98$.

SOLUTION:-

Given data:

$$\text{Head, } H = 10 \text{ m}$$

$$\text{Dia. of orifice, } d = 40 \text{ mm} = 0.04 \text{ m}$$

$$\therefore \text{Area of orifice, } a = \frac{\pi}{4} (d)^2 = \frac{\pi}{4} (0.04)^2 = 0.001256 \text{ m}^2$$

$$C_d = 0.6 \text{ and } C_v = 0.98$$

(i) As we know,

$$C_d = \frac{\text{Actual discharge}}{\text{Theoretical discharge}} = 0.6$$

$$\Rightarrow \text{Actual discharge} = 0.6 \times Q_{th}$$

$$\text{But, } Q_{th} = V_{th} \times a_{th}$$

$$\text{And } V_{th} = \sqrt{2gH} = \sqrt{2 \times 9.81 \times 10} = 14 \text{ m/s}$$

$$\text{Theoretical discharge, } Q_{th} = 14 \times 0.001256 = 0.01758 \text{ m}^3/\text{s}$$

$$\text{Actual discharge, } Q_{act.} = 0.6 \times 0.01758$$

$$= 0.01054 \text{ m}^3/\text{s}$$

$$(ii) C_v = 0.98 = \frac{\text{Actual velocity}}{\text{Theoretical velocity}}$$

$$\Rightarrow \text{Actual velocity} = 0.98 \times V_{th}$$

$$= 0.98 \times 14$$

$$= 13.72 \text{ m/s}$$

PROBLEM

The head of water over the centre of an orifice of diameter 20 mm is 1 m. The actual discharge through the orifice is 0.85 lit./s. Find the co-efficient of discharge.

SOLUTION:-

Given data:

Dia. of orifice, $d = 20 \text{ mm} = 0.02 \text{ m}$

$$\therefore \text{Area of orifice, } a = \frac{\pi}{4} (d)^2 = \frac{\pi}{4} (0.02)^2 = 0.000314 \text{ m}^2$$

Head, $H = 1 \text{ m}$

Actual discharge, $Q = 0.85 \text{ ltr/s}$

$$= \frac{0.85}{1000} \text{ m}^3/\text{s}$$

$$= 0.00085 \text{ m}^3/\text{s}$$

$$\text{Theoretical velocity, } V_{th} = \sqrt{2gH} = \sqrt{2 \times 9.81 \times 1} = 4.429 \text{ m/s}$$

Theoretical discharge, $Q_{th} = V_{th} \times \text{Area of orifice}$

$$= 4.429 \times 0.000314$$

$$= 0.00139 \text{ m}^3/\text{s}$$

$$\text{Co-efficient of discharge, } C_d = \frac{\text{Actual discharge}}{\text{Theoretical discharge}} = \frac{0.00085}{0.00139} = 0.61$$

EXPERIMENTAL DETERMINATION OF HYDRAULIC CO-EFFICIENTS

Determination of C_d :-

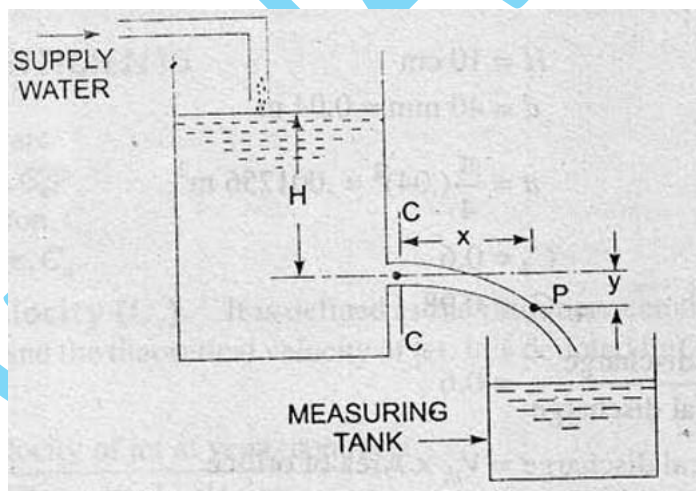

The water is allowed to flow through an orifice fitted to a tank under a constant head. The water is collected in a measuring tank for a known time t is noted down and the height of the measuring tank also noted down. Then actual discharge through the orifice.

$$Q_{act.} = \frac{\text{Area of measuring tank (A)} \times \text{Height of the measuring tank (H)}}{\text{Time (t)}}$$

And theoretical discharge, $Q_{th} = \text{Area of orifice} \times \text{Theoretical velocity}$

$$a \times \sqrt{2gH}$$

So, co-efficient of discharge, $C_d = \frac{Q_{act}}{Q_{th}} = \frac{Q_{act}}{a \times \sqrt{2gH}}$

Determination of co-efficient of velocity (C_v):-

Let, C-C represents the vena-contracta of a jet of water coming out from an orifice under constant head H . Consider a liquid particle which is at vena-contracta at any time and takes the position at P along the jet in time t .

Let, x = horizontal distance travelled by the particle in time t .

y = Vertical distance between P and C-C.

v = Actual velocity of jet at vena-contracta.

The horizontal distance, $x = v \times t$

$$t = \frac{x}{v}$$

and vertical distance, $y = \frac{1}{2}g t^2 = \frac{1}{2}g \left(\frac{x}{v}\right)^2$

$$\Rightarrow v^2 = \frac{g x^2}{2y}$$

$$\Rightarrow \text{Actual velocity, } v = \sqrt{\frac{g x^2}{2y}}$$

But theoretical velocity, $V_{th} = \sqrt{2gH}$

$$\begin{aligned} \text{So, co-efficient of velocity, } C_v &= \frac{v_{act.}}{v_{th.}} = \frac{\sqrt{\frac{g x^2}{2y}}}{\sqrt{2gH}} = \sqrt{\frac{g x^2}{2y}} \times \frac{1}{\sqrt{2gH}} \\ &= \sqrt{\frac{x^2}{4yH}} \end{aligned}$$

$$\Rightarrow C_v = \frac{x}{\sqrt{4yH}}$$

Determination of co-efficient of contraction (C_c):-

As we know $C_d = C_v \times C_c$

$$C_c = \frac{C_d}{C_v}$$

PROBLEM

A jet of water, issuing from a sharp-edged vertical orifice under a constant head of 10 cm, at a certain point, has the horizontal and vertical co-ordinates measured from the vena-contracta as 20 cm and 10.5 cm respectively. Find the value of C_v , also find the value of C_c and $C_d = 0.60$.

SOLUTION

Given data:

Head, $H = 10$ cm

Horizontal distance, $x = 20$ cm

Vertical distance, $y = 10.5$ cm

Co-efficient of discharge, $C_d = 0.6$

$$\text{We know that, } C_v = \frac{x}{\sqrt{4yH}} = \frac{20}{\sqrt{4 \times 10.5 \times 10}} = \frac{20}{20.493} = 0.976$$

$$\text{And } C_c = \frac{C_d}{C_v} = \frac{0.6}{0.976} = 0.6147$$

PROBLEM

The head of water over an orifice of diameter 100 mm is 10 m. The water is coming out from orifice is collected in a circular tank of diameter 1.5 m in 25 sec. Also the co-ordinates of a point on the jet, measured from vena-contracta are 4.3 m horizontal and 0.5 m vertical. Find the co-efficients, C_c , C_v and C_d .

SOLUTION:-

Given data:

Head, $H = 10$ m

Diameter of orifice, $d = 100$ mm = 0.1 m.

$$\therefore \text{Area of orifice, } a = \frac{\pi}{4}(d)^2 = \frac{\pi}{4}(0.1)^2 = 0.007853 \text{ m}^2$$

Diameter of measuring tank, $D = 1.5$ m

$$\therefore \text{Area of measuring tank, } A = \frac{\pi}{4}(D)^2 = \frac{\pi}{4}(1.5)^2 = 1.767 \text{ m}^2$$

Rise of water, $h = 1$ m

In time, $t = 25$ sec.

Horizontal distance, $x = 4.3$ m

Vertical distance, $y = 0.5$ m

Now theoretical discharge,

$$Q_{th.} = V_{th.} \times \text{Area of orifice}$$

$$= 14 \times 0.007854 = 0.1099 \text{ m}^3/\text{s}$$

$$\text{Actual discharge, } Q_{act.} = \frac{A \times h}{t} = \frac{1.767 \times 1}{25} = 0.07068 \text{ m}^3/\text{s}$$

$$\text{So } C_d = \frac{Q_{act.}}{Q_{th.}} = \frac{0.07068}{0.1099} = 0.643$$

$$\text{The value of } C_v = \frac{x}{\sqrt{4yH}} = \frac{4.3}{\sqrt{4 \times 0.5 \times 10}} = 0.96$$

$$C_C = \frac{C_d}{C_v} = \frac{0.643}{0.96} = 0.669$$

PROBLEM

Water discharge at the rate of 98.2 lit/s through a 120 mm diameter, vertical sharp edged orifice placed under a constant head of 10 m. A point on the jet measured from the vena-contracta of the jet has co-ordinates 4.5 m horizontal and 0.54 vertical. Find the co-efficients C_c , C_v and C_d of the orifice.

SOLUTION:-

Given data:

Discharge, $Q = 98.2 \text{ lit/s}$

$$= \frac{98.2}{1000} = 0.0982 \text{ m}^3/\text{s}$$

Dia. of orifice, $d = 120 \text{ mm} = 0.120 \text{ m}$

$$\text{Area of orifice, } a = \frac{\pi}{4} (d)^2 = \frac{\pi}{4} (0.12)^2 = 0.01131 \text{ m}^2$$

Head, $H = 10 \text{ m}$

Horizontal distance of a point on the jet from vena-contracta, $x = 4.5 \text{ m}$

And vertical height, $y = 0.54 \text{ m}$

Now theoretical velocity, $V_{th} = \sqrt{2gH} = \sqrt{2 \times 9.81 \times 10} = 14 \text{ m/s}$

Theoretical discharge, $Q_{th} = V_{th} \times \text{Area of orifice (a)} = 14 \times 0.01131 = 0.1583 \text{ m}^3/\text{s}$

$$\text{The value of } C_d = \frac{Q_{act.}}{Q_{th.}} = \frac{0.0982}{0.1583} = 0.62$$

$$\text{The value of } C_v = \frac{x}{\sqrt{4yH}} = \frac{4.5}{\sqrt{4 \times 0.54 \times 10}} = 0.968$$

$$\text{The value of } C_C = \frac{C_d}{C_v} = \frac{0.62}{0.968} = 0.64$$

DISCHARGE THROUGH LARGE RECTANGULAR ORIFICE

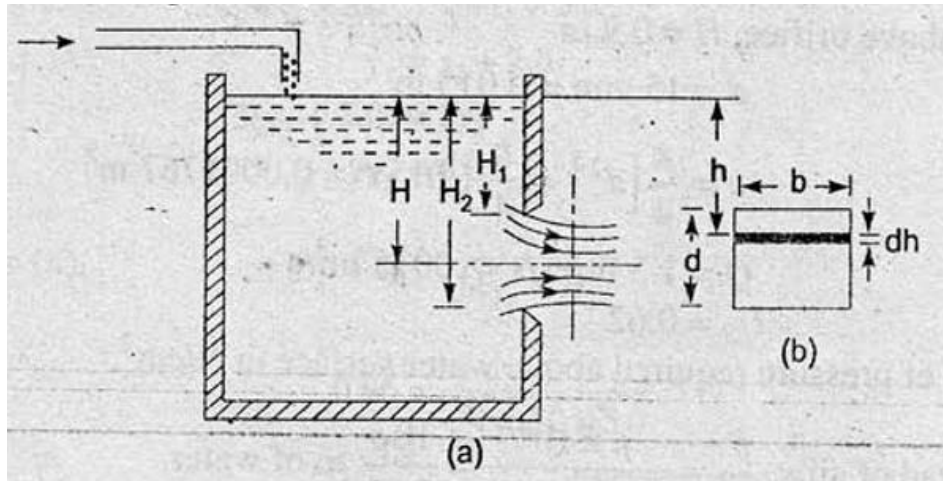

Consider a large rectangular orifice in one side of the tank discharging freely in to atmosphere under a constant head **H**.

Let H_1 = Height of liquid above top edge of orifice.

H_2 = Height of liquid above bottom edge of orifice.

b = breadth of orifice.

d = depth of orifice = $H_2 - H_1$

C_d = co-efficient of discharge.

Consider an elementary horizontal strip of depth dh at a depth of h below the free surface of the liquid in the tank.

Area of strip = $b \times dh$

The theoretical velocity of water through strip = $\sqrt{2gh}$

Discharge through elementary strip

$$dQ = C_d \times \text{area of strip} \times \text{velocity}$$

$$= C_d \times b \times dh \times \sqrt{2gh}$$

$$= C_d \times b \times \sqrt{2gh} \cdot dh$$

By integrating the above equation between the limits H_1 and H_2 , the total discharge through the whole orifice will obtained.

$$Q = \int_{H_1}^{H_2} dQ = \int_{H_1}^{H_2} C_d \times b \times \sqrt{2gh} \cdot dh$$

$$= C_d \times b \times \sqrt{2g} \int_{H_1}^{H_2} \sqrt{h} \cdot dh$$

$$= C_d \times b \times \sqrt{2g} \int_{H_1}^{H_2} h^{\frac{1}{2}} \cdot dh$$

$$C_d \times b \times \sqrt{2g} \left[\frac{h^{3/2}}{3/2} \right]_{H_1}^{H_2}$$

$$= \frac{2}{3} C_d \times b \sqrt{2g} [H_2^{3/2} - H_1^{3/2}]$$

PROBLEM

Find the discharge through a rectangular orifice of 2 m wide and 1.5 m deep fitted to a water tank. The water level in the tank is 3 m above the top edge of the orifice. Take $C_d = 0.62$.

SOLUTION

Given data:

Width of the orifice, $b = 2$ m

Depth of orifice, $d = 1.5$ m

Height of the water above top of the orifice, $H_1 = 3$ m

Height of water above bottom edge of the orifice, $H_2 = 3 + 1.5 = 4.5$ m

Co-efficient of discharge. $C_d = 0.62$

Discharge, Q is given by

$$= \frac{2}{3} C_d \times b \sqrt{2g} [H_2^{3/2} - H_1^{3/2}]$$

$$= \frac{2}{3} \times 0.62 \times 2 \times \sqrt{2 \times 9.81} [(4.5)^{3/2} - (3)^{3/2}]$$

$$= 3.66 \times (9.545 - 5.196)$$

$$= 15.917 \text{ m}^3/\text{s}$$

PROBLEM

A rectangular orifice, 1.5 m wide and 1 m deep is discharging water from a tank, if the water level in the tank is 3 above the top edge of the orifice. Find the discharge through the orifice. Take the co-efficient of discharge for the orifice = 0.6.

PROBLEM

A rectangular orifice, 0.9 m wide and 1.2 m deep is discharging water from a vessel. The top edge of the orifice is 0.6 m below the water surface in the vessel. Calculate the discharge through the orifice, if the co-efficient of discharge for the orifice = 0.6 and percentage of error if the orifice is treated as a small orifice.

SOLUTION

Given data:

Width of the orifice, $b = 0.9$ m

Depth of orifice, $d = 1.2$ m

Height of the water above top of the orifice, $H_1 = 0.6$ m

Height of water above bottom edge of the orifice, $H_2 = 1.2 + 0.6 = 1.8$ m

Co-efficient of discharge. $C_d = 0.6$

Discharge, Q is given by

$$\begin{aligned} &= \frac{2}{3} C_d \times b \sqrt{2g} [H_2^{3/2} - H_1^{3/2}] \\ &= \frac{2}{3} \times 0.6 \times 0.9 \times \sqrt{2 \times 9.81} [(1.8)^{3/2} - (0.6)^{3/2}] \\ &= 1.5946 \times (2.4249 - 0.4647) \\ &= 3.1097 \text{ m}^3/\text{s} \end{aligned}$$

Discharge for a small orifice

$$Q_1 = C_d \times a \times \sqrt{2gh}$$

$$\text{Where, } h = H_1 + \frac{d}{2}$$

$$= 0.6 + \frac{1.2}{2} = 1.2 \text{ m}$$

$$\text{And } a = b \times d = 0.9 \times 1.2$$

$$\begin{aligned} \text{So } Q_1 &= 0.6 \times 0.9 \times 1.2 \times \sqrt{2 \times 9.81 \times 1.2} \\ &= 3.1442 \text{ m}^3/\text{s} \end{aligned}$$

$$\begin{aligned} \% \text{ of error} &= \frac{Q_1 - Q}{Q} = \frac{3.1442 - 3.1097}{3.1097} \times 100 \\ &= 0.01109 \times 100 \\ &= 1.109 \% \end{aligned}$$

NOTCHES

A notch is a device used for measuring the rate of flow of a liquid through a small channel or a tank.

It may be defined as an opening in the side of a tank or a small channel in such a way that the liquid surface in the tank or channel is below the top edge of the opening.

Classification of Notches

According to shape of the opening:

- (a) Rectangular notch
- (b) Triangular notch
- (c) Trapezoidal notch

(d) Stepped notch

According to shape of the effect of the sides on the nappe:

(a) Notch with end contraction

(b) Notch without contraction / Suppressed notch

Nappe/ Vein

The sheet of water flowing through a notch over a wire is called vein or nappe.

Crest/ Sill

The bottom edge of a notch over which the water flows, is called crest or sill.

Difference between orifice and notch

Orifice

→ It is used to measure rate of flow or discharge of liquid.

→ It is a small opening of any cross section on the side or at the bottom of the tank through which fluid flows.

→ It may be rectangular, triangular, square or circular.

Notch

→ It is used to measure the rate of flow of liquid through a small channel or tank.

→ It may be defined as an opening in the side of a small tank or channel in such a way that the liquid surface in the tank is below the top edge of opening.

→ It may be rectangular, triangular, trapezoidal or stepped.

Discharge over a rectangular notch

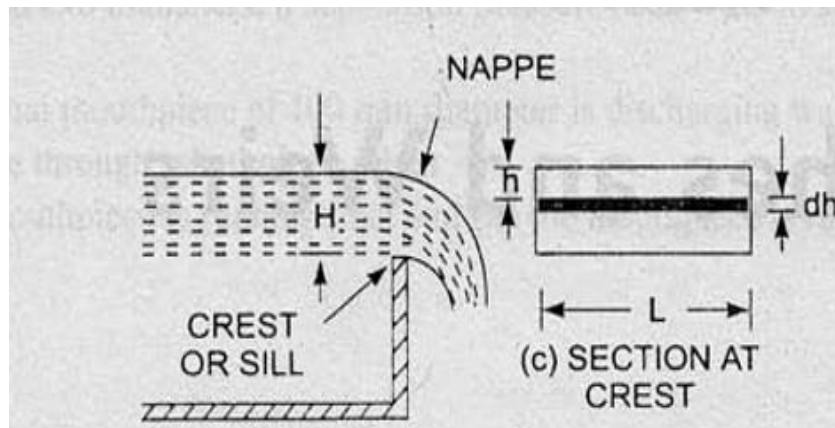

Consider a rectangular notch provided in a channel carrying water.

Let, H = Head of water over the crest.

L = Length of the notch.

For finding the discharge of water flowing over the notch. Consider an elementary horizontal strip of water of thickness dh and length L at a depth h from the free surface of water.

Area of strip = $L \times dh$

Theoretical velocity of water flowing through strip is = $\sqrt{2gh}$

The actual discharge dQ through strip is

$dQ = C_d \times \text{area of strip} \times \text{theoretical velocity}$

$$\Rightarrow dQ = C_d \times L \times dh \times \sqrt{2gh}$$

The total discharge Q for the whole notch is determined by integrating the above equation between limit 0 and H , we get

$$\begin{aligned} \int_0^H dQ &= \int_0^H C_d \times L \times dh \times \sqrt{2gh} \\ &= C_d \times L \times \sqrt{2g} \int_0^H \sqrt{h} \cdot dh \end{aligned}$$

$$= C_d \times L \times \sqrt{2g} \left[\frac{h^{1/2+1}}{\frac{1}{2}+1} \right]_0^H = C_d \times L \times \sqrt{2g} \left[\frac{h^{3/2}}{3/2} \right]_0^H$$

$$= C_d \times L \times \sqrt{2g} \times \frac{H^{3/2}}{\frac{3}{2}}$$

$$Q = \frac{2}{3} \times C_d \times L \times \sqrt{2g} \times H^{3/2}$$

This is the equation for total discharge through rectangular notch.

PROBLEM

Determine the height of a rectangular notch/weir of length 6 m to be built across rectangular channel. The maximum depth of water on the upstream side of the notch is 1.8 m and discharge is 2000 lit/s. Take $C_d = 0.6$ and neglect the end contraction.

SOLUTION:-

Given data:

Length of notch, $L = 6$ m.

Depth of water, $H_1 = 1.8$ m.

Discharge, $Q = 2000$ lit/s = 2 m³/s

Let, H = Height of water above the crest of notch and

H_2 = Height of weir/ notch

The discharge over the notch is given by the equation as

$$Q = \frac{2}{3} \times C_d \times L \times \sqrt{2g} \times H^{\frac{3}{2}}$$

So,
$$2 = \frac{2}{3} \times 0.6 \times 6 \times \sqrt{2 \times 9.81} \times H^{\frac{3}{2}}$$

$$\Rightarrow 2 = 10.623 \times H^{\frac{3}{2}}$$

$$\Rightarrow H^{\frac{3}{2}} = \frac{2}{10.623}$$

$$\Rightarrow H = 0.328$$
 m

$$\therefore \text{Height of weir, } H_2 = H_1 - H = 1.8 - 0.328 = 1.472$$

PROBLEM

Find the discharge of water flowing over a rectangular notch of 2 m length when the constant head over the notch is 300 mm. Take $C_d = 0.60$.

SOLUTION:-

Given data:

Length of the notch, $L = 2$ m.

Head over notch, $H = 300$ mm = 0.3 m.

And $C_d = 0.6$

Discharge,
$$Q = \frac{2}{3} \times C_d \times L \times \sqrt{2g} \times H^{\frac{3}{2}}$$

$$= \frac{2}{3} \times 0.6 \times 2 \times \sqrt{2 \times 9.81} \times (0.3)^{\frac{3}{2}} = 0.582 \text{ m}^3/\text{s}$$

PROBLEM

The head of water over a rectangular notch is 900 mm. The discharge is 300 lit/s. Find the length of the notch, when $C_d = 0.60$.

SOLUTION:-

Given data:

Head over notch, $H = 900 \text{ mm} = 0.9 \text{ m}$.

And $C_d = 0.6$

Discharge, $Q = 300 \text{ lit/s} = 0.3 \text{ m}^3/\text{s}$

And length of notch, $L = ?$

According to the discharge formula

$$Q = \frac{2}{3} \times C_d \times L \times \sqrt{2g} \times H^{\frac{3}{2}}$$

$$0.3 = \frac{2}{3} \times 0.6 \times L \times \sqrt{2 \times 9.81} \times (0.9)^{\frac{3}{2}}$$

$$L = 0.192 \text{ m} = 192 \text{ mm}.$$

Discharge over a triangular notch/ weir

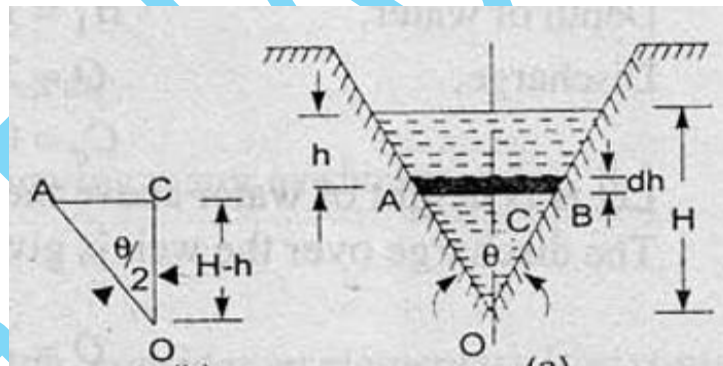

Let H = head of water above V- notch.

θ = angle of notch.

Consider a horizontal strip of water of thickness dh at a depth of h from the free surface of water.

$$\text{We have } \tan \frac{\theta}{2} = \frac{AC}{OC} = \frac{AC}{(H-h)}$$

$$\Rightarrow AC = (H-h) \tan \frac{\theta}{2}$$

$$\text{Width of strip } AB = 2 AC = 2 (H-h) \tan \frac{\theta}{2}$$

Let this strip consider as rectangle, so area of strip = $2 (H-h) \tan \frac{\theta}{2} \times dh$

Theoretical velocity of water through the strip = $\sqrt{2gh}$

Actual discharge **dQ** through the strip

$dQ = C_d \times \text{Area of strip} \times \text{theoretical velocity of the strip}$

$$= C_d \times 2 (H-h) \tan \frac{\theta}{2} \times dh \times \sqrt{2gh}$$

$$= 2 \times C_d \times (H-h) \tan \frac{\theta}{2} \times \sqrt{2gh} .dh$$

We can get the total discharge Q by integrating the above equation from 0 to H.

$$Q = \int_0^H 2 \times C_d \times (H-h) \tan \frac{\theta}{2} \times \sqrt{2gh} .dh$$

$$= 2 \times C_d \times \tan \frac{\theta}{2} \times \sqrt{2g} \int_0^H (H-h) \sqrt{h} .dh$$

$$= 2 \times C_d \times \tan \frac{\theta}{2} \times \sqrt{2g} \int_0^H (H \cdot h^{1/2} - h^{3/2}) .dh$$

$$= 2 \times C_d \times \tan \frac{\theta}{2} \times \sqrt{2g} \left[\frac{Hh^{3/2}}{3/2} - \frac{h^{5/2}}{5/2} \right]_0^H$$

$$= 2 \times C_d \times \tan \frac{\theta}{2} \times \sqrt{2g} \left[\frac{2}{3} H^1 \cdot H^{3/2} - \frac{2}{5} H^{5/2} \right]$$

$$= 2 \times C_d \times \tan \frac{\theta}{2} \times \sqrt{2g} \left[\frac{2}{3} H^{5/2} - \frac{2}{5} H^{5/2} \right]$$

$$= 2 \times C_d \times \tan \frac{\theta}{2} \times \sqrt{2g} \times \left[\frac{4}{15} \times H^{5/2} \right]$$

$$\Rightarrow Q = \frac{8}{15} \times C_d \times \tan \frac{\theta}{2} \times \sqrt{2g} \times H^{5/2}$$

For a right angled V- notch, if $C_d = 0.6$, $\theta = 90^\circ$, $\tan \frac{\theta}{2} = 1$

$$\text{So, discharge } Q = \frac{8}{15} \times 0.6 \times 1 \times \sqrt{2 \times 9.81} \times H^{5/2}$$

$$\Rightarrow Q = 1.417H^{5/2}$$

PROBLEM

Find the discharge over a triangular notch of angle 60° , when the head over the V- notch is 0.3 m. Assume $C_d = 0.6$.

SOLUTION:-

Given data:

Angle of V-notch, $\theta = 60^\circ$

Head over notch, $H = 0.3$ m

And $C_d = 0.6$

Angle of V-notch is given by the equation

$$\begin{aligned} Q &= \frac{8}{15} \times C_d \times \tan \frac{\theta}{2} \times \sqrt{2g} \times H^{5/2} \\ &= \frac{8}{15} \times 0.6 \times \tan \frac{60^\circ}{2} \times \sqrt{2 \times 9.81} \times (0.3)^{5/2} \\ &= 0.8182 \times 0.0493 \\ &= 0.040 \text{ m}^3/\text{s} \end{aligned}$$

PROBLEM

Water flows over a rectangular weir 1m wide at a depth of 150 mm and afterward passes through a triangular right-angled weir. Taking C_d for the rectangular and triangular weir as 0.62 and 0.59 respectively, find the depth over the triangular weir.

SOLUTION:-

Given data:

For rectangular weir

$$\text{Length, } L = 1 \text{ m}$$

$$\text{Height, } H = 150 \text{ mm} = 0.15 \text{ m}$$

$$\text{And } C_d = 0.62$$

For triangular weir

$$\text{Angle of V-notch, } \theta = 90^\circ$$

$$\text{Head over notch, } H = ?$$

$$\text{And } C_d = 0.59$$

The discharge over the rectangular weir is given by

$$\begin{aligned} Q &= \frac{2}{3} \times C_d \times L \times \sqrt{2g} \times H^{3/2} \\ &= \frac{2}{3} \times 0.62 \times 1 \times \sqrt{2 \times 9.81} \times (0.15)^{3/2} \\ &= 0.01635 \text{ m}^3/\text{s} \end{aligned}$$

The same discharge passes through the triangular weir, so for triangular weir

$$\begin{aligned} 0.01635 &= \frac{8}{15} \times C_d \times \tan \frac{\theta}{2} \times \sqrt{2g} \times H^{5/2} \\ \Rightarrow 0.01635 &= \frac{8}{15} \times 0.59 \times \tan \frac{90^\circ}{2} \times \sqrt{2 \times 9.81} \times H^{5/2} \\ \Rightarrow H^{5/2} &= \frac{0.01635 \times 15}{8 \times 0.59 \times 1 \times \sqrt{2 \times 9.81}} = 0.07631 \\ \Rightarrow H &= (0.07631)^{2/5} = 0.3572 \text{ m} \end{aligned}$$

LOSSES OF HEAD DUE TO FLUID FRICTION

The major loss of energy due to friction and is calculated by following formula

- (i) Darcy weisbach formula
- (ii) Chezy's formula.

(i) Darcy weisbach formula:

$$h_f = \frac{4fLV^2}{2gd}$$

Where h_f = Loss of head due to friction.

f = co-efficient of friction which is a function of Reynolds number.

$$f = \frac{16}{Re} \quad (\text{when flow of fluid is laminar})$$

$$f = \frac{0.079}{Re^{1/4}} \quad (\text{when flow of fluid is turbulent})$$

L = Length of the pipe.

V = Mean velocity of fluid flow.

d = diameter of pipe.

Reynolds number

$Re < 2000$ = Laminar flow

$Re > 2000$ = Turbulent flow

$Re = 2000 - 4000$ = transition flow

$$Re = \frac{v \times d}{\gamma}$$

Where, V = velocity of fluid flow.

d = diameter of pipe.

and γ = viscosity of fluid.

ii. Chezy's formula

$$V = C\sqrt{mi}$$

$$m = \frac{d}{4}, \quad i = \frac{hf}{L}$$

Where V = mean velocity of flow.

C = chezy' s constant

and i = Loss of head of unit length of pipe.

PROBLEM

Find the head loss due to the friction in pipe of diameter of 300 mm and length 50 m through which water is flowing at a velocity of 3 m/s using Darcy webach formula and Chezy's formula . Find the head loss where Chezy's constant $C = 60$ and γ of water is 0.01 stoke.

SOLUTION:-

Given data:

Diameter of pipe, $d = 300 \text{ mm} = 0.3 \text{ m}$

Length of pipe, $L = 50 \text{ m}$

Velocity of the water, $V = 3 \text{ m/s}$

Chezy's constant, $C = 60$ (1 stoke = $1 \text{ cm}^2/\text{s}$)

Kinematic viscosity, $\gamma = 0.01 \text{ stoke} = 0.01 \times 10^{-4} \text{ m}^2/\text{s}$

By applying Darcy webach formula to calculate head loss due to friction

$$\text{So } h_f = \frac{4fLV^2}{2gd}$$

Here f = co-efficient of friction which is a function of Reynolds number R_e

$$R_e = \frac{V \times d}{\gamma} = \frac{3 \times 0.3}{0.01 \times 10^{-4}} = 9 \times 10^5$$

$$\text{So, } f = \frac{0.079}{R_e^{1/4}} = \frac{0.079}{(9 \times 10^5)^{1/4}} = 0.00256$$

$$\text{So head loss, } h_f = \frac{4fLV^2}{2gd} = \frac{4 \times 0.00256 \times 50 \times 3^2}{2 \times 9.81 \times 0.3} = 78.28 \text{ m}$$

(ii) Now applying Chezy's formula to calculate h_f

$$V = C\sqrt{mi}$$

$$m = d/4 = 0.3/4 = 0.075 \text{ m}$$

and i = loss of head of unit length of pipe

$$i = \frac{hf}{L} = \frac{hf}{50}$$

$$\Rightarrow v = 60 \times \sqrt{0.075 \times \frac{hf}{50}}$$

$$\Rightarrow 3 = 60 \times \sqrt{0.075 \times \frac{hf}{50}}$$

$$\Rightarrow hf = 1.66 \text{ m}$$

Hydraulic gradientline:-

It is defined as the sum of pressure head $\left(\frac{P}{\rho g}\right)$ and datum head (z) of the flowing fluid of a pipe with respect to reference line.

It is obtained by joining the top of all vertical ordinates, showing the pressure head of a flowing fluid in a pipe from the centre of pipe.

Total energy line :-

It is defined as the energy line which is sum of pressure head $\left(\frac{P}{\rho g}\right)$, kinetic head $\left(\frac{V^2}{2g}\right)$ datum head (Z), of a flowing fluid in a pipe with respect to some reference line.

It is obtained by joining the top of all vertical ordinates showing the sum of pressure head, kinetic head from the centre of pipe.

Laws of fluid friction

First law:-

The fluid friction increases with the increase in the area of contact between the surface and fluid.

Second law:-

The fluid friction increases with an increase in the velocity gradient of the substance.

Third law:-

The fluid having a higher co-efficient of fluid friction has a higher value of fluid frictional force.

CHAPTER 3. COMPRESSED AIR

Compressed air is [air](#) kept under a [pressure](#) that is greater than [atmospheric pressure](#). Compressed air is an important medium for transfer of energy in industrial processes, and is used for [power tools](#) such as [air hammers](#), [drills](#), [wrenches](#) and others, as well as to atomize paint, to operate air cylinders for automation, and can also be used to propel vehicles. Brakes applied by compressed air made large railway trains safer and more efficient to operate. Compressed air brakes are also found on large highway vehicles.

Classification of compressor:

Following are the types of air compressors:

1. Reciprocating air compressor
2. Rotary air compressor
3. Centrifugal air compressor
4. Axial air compressor

1. Reciprocating Air Compressor

A reciprocating air compressor is a type of positive displacement compressor that uses a piston. The [piston is driven by the crankshaft](#) to transfer the high-pressure gases into the cylinder.

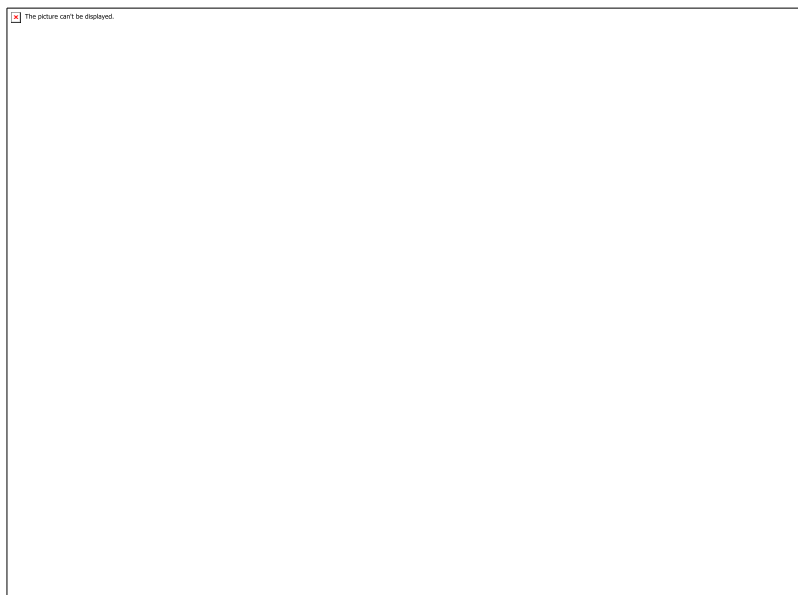

In these types of air compressors, initially, the gas enters from the suction [manifold](#). This gas is flowing through a compression cylinder where it gets compressed by an attached piston. It is driven in a reciprocating motion by the application of a crankshaft, and it is released.

~~As a result, it can remove air from a 750KVA air conditioning system.~~

When compared to a regular diaphragm compressor, it has a longer lifespan and requires quiet maintenance because of continuous use. A reciprocating compressor is used in gas pipelines, chemical plants, [air conditioning](#), and refrigeration plants.

2. Rotary Air Compressor

A rotary air compressor, which is the simplest compressor, consists of two rotors with lobes rotating in an air-tight casing that has an inlet and outlet ports. Its action resembles that of a gear pump.

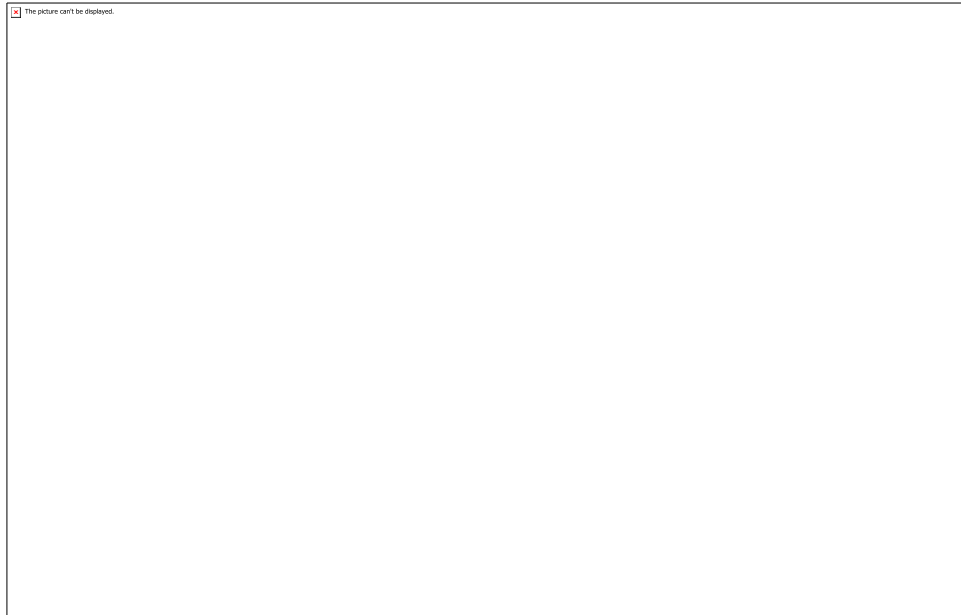

There are many designs of a wheel, but they generally have two or three lobes. The lobes are made that they provide an air-tight joint at their point of contact.

As the rotors rotate, the air is drawn from the receiver into the space between the lobes and

The rotary motion of the lobes delivers the entered air into the receiver. Thus greater flow of air in the receiver increases its pressure. Finally, the air is delivered from the receiver at high pressure.

3. Centrifugal Air Compressor

A centrifugal blower compressor is a common type, has a rotor (or impeller), in which several types of curved vanes are arranged symmetrically. The rotor revolves in an air-tight casing with inlet and outlet points.

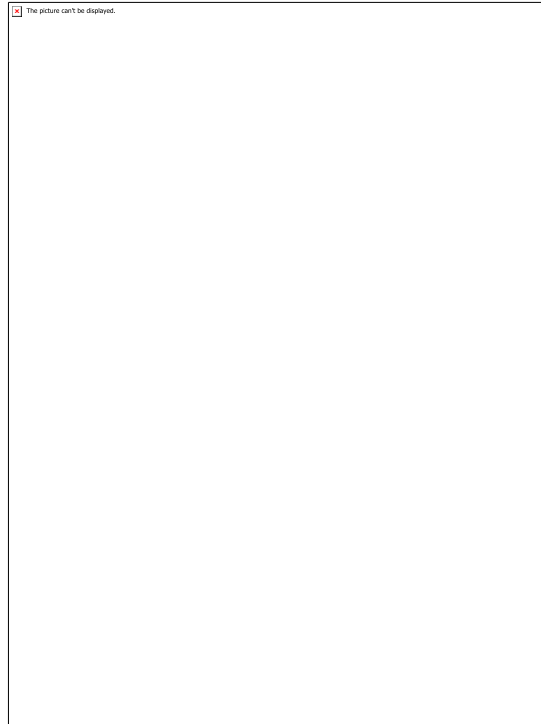

In these types of air compressors, the casing for the compressor is so designed that the kinetic energy of the air is converted into pressure energy before it leaves the casing as shown in the figure. Mechanical energy is given to the rotor from an external source.

As the rotor rotates, it absorbs air through its eye, increases its pressure due to centrifugal force, and pushes air to flow across the diffuser. The air pressure increases further during its flow on the diffuser.

Finally, the air at high pressure is delivered to the receiver. It would remain interesting to know that air enters the impeller radially and discharge the vane axially.

4. Axial Air Compressor

Which of the following is not a method for the storage of compressed air?



The blades are produced of an aerofoil section to lower the loss created by turbulence and boundary separation. Mechanical energy is given to the rotating shaft, which turns the drum.

The air comes from the left side of the compressor. As the drum begins to rotate, air flows through the arranged stator and rotor. As the air flows from one set of stators and rotors to another, it gets compressed.

Thus successive compression of the air, in all the sets of stator and rotor, the air is delivered at high pressure at the outlet point.

Various methods of storage and transmission of compressed air

Air storage vessels vary in the thermodynamic conditions of the storage and on the technology used:

1. Constant volume storage (solution mined caverns, above ground vessels, aquifers, automotive applications, etc.)
2. Constant pressure storage (underwater pressure vessels, hybrid pumped hydro - compressed air storage)

Constant-volume storage

This storage system uses a chamber with specific boundaries to store large amounts of air. This means from a thermodynamic point of view that this system is a constant-volume and variable-pressure system.

Constant-pressure storage

In this case, the storage vessel is kept at constant pressure, while the gas is contained in a variable-volume vessel. The storage vessel is positioned hundreds of meters underwater, and the hydrostatic pressure of the water column above the storage vessel allows maintaining the pressure at the desired level.

Transmission of compressed air mainly occurs through pipes and hoses. Pipe is used where need rigid connection from the receiver and hoses are used where need flexible connection.

Advantages of use of compressed air in mines

USES OF COMPRESSED AIR IN MINES

1. Powering Air Tools

The equipment in a mine must be built for heavy-duty applications. Fittingly, there are compressed [air tools](#) and devices designed specifically for usage in mines. Some equipment used in mining are:

- - **Drills and Jackhammers** – for exploration drilling, probing surrounding areas for ore, breaking rock walls or other stubborn materials
 - **Impact Wrenches** – for adjusting equipment and tightening or loosening bolts accordingly
 - **Hoists** – for lifting equipment, large rocks, and (occasionally) personnel

In addition, compressed air systems can be fitted with **filters** to ensure that only clean, dust-free air enters the tools in a mining site.

2. Blasting

Blasting refers to the controlled use of explosives to break up the rock. These explosives are often loaded into cylinders which have been embedded into the rock bed. Compressed air tools can easily drill holes into the rock, while compressed air itself can push explosives into the prepared cylinders.

3. Transporting Materials

Fine, powdery materials such as coal dust would normally be difficult to transport around a mining site using gravity alone. However, an upstream of compressed air causes such materials to behave like fluids and flow down slight inclines. This phenomenon is called fluidization, the principle behind air slide conveyors. Roots blowers are often used for this application.

4. Cleaning

Compressed air can also clear accumulated dust from filters and other equipment in the mine. This helps increase the service life of mining equipment and reduce the time needed for routine maintenance. It also eliminates the need for other cleaning materials.

5. Ventilating Mining Sites

One key application of compressed air is providing adequate ventilation in deep mine tunnels. Fumes and dust can pose health risks to miners working in an enclosed space. [Roots blowers](#) in an airflow system can transport these hazardous gases and particles away from the working area.

Compressed air is also important for a mine's [refuge stations](#). During fires and other dangerous incidents, miners can stay in a refuge station fitted with basic life support services and communication lines.

6. Extracting Methane Gas and Coal Dust

Aside from being poisonous to miners, methane and coal dust are both highly flammable. An electric spark can be enough to cause an explosion if these two substances have accumulated in a given mine.

Fortunately, a properly designed compressed air system can easily extract methane and coal dust and reduce the risks of an explosion. You'll want to have a compressed air system fitted with blowers and vacuum pumps for this application.

7. Handling Waste Properly

Some mines are equipped with wastewater treatment facilities to reduce their environmental impact. In line with this, aeration blowers are often used to remove carbon dioxide from the water. The introduction of clean compressed air into wastewater can also help organic compounds metabolize.

Advantages:

- **High effectiveness** – There is an unlimited supply of air in the atmosphere to produce compressed air. Also there is the possibility of easy storage in large volumes. The use of compressed air is not restricted by distance, as it can easily be transported through pipes. After use, compressed air can be released directly into the atmosphere without the need of processing.
- **High durability and reliability** – Pneumatic system components are extremely durable and cannot be damaged easily. Compared to electromotive components, pneumatic components are more durable and reliable.
- **Simple design** – The designs of pneumatic system components are relatively simple. They are thus more suitable for use in simple automatic control

systems. There is choice of movement such as linear movement or angular rotational movement with simple and continuously variable operational speeds.

- **High adaptability to harsh environment** – Compared to the elements of other systems, compressed air is less affected by high temperature, dust, and corrosive environment, etc. Hence they are more suitable for harsh environment.
- **Safety aspects** – Pneumatic systems are safer than electromotive systems because they can work in inflammable environment without causing fire or explosion. Apart from that, overloading in pneumatic system only leads to sliding or cessation of operation. Unlike components of electromotive system, pneumatic system components do not burn or get overheated when overloaded.
- **Easy selection of speed and pressure** – The speeds of rectilinear and oscillating movement of pneumatic systems are easy to adjust and subject to few limitations. The pressure and the volume of the compressed air can easily be adjusted by a pressure regulator.
- **Environmental friendly** – The operation of pneumatic systems do not produce pollutants. Pneumatic systems are environmentally clean and with proper exhaust air treatment can be installed to clean room standards. Therefore, pneumatic systems can work in environments that demand high level of cleanliness. One example is the production lines of integrated circuits.
- **Economical** – As the pneumatic system components are not expensive, the costs of pneumatic systems are quite low. Moreover, as pneumatic systems are very durable, the cost of maintenance is significantly lower than that of other systems.

i) Pneumatic rock drill:

Generally in all pneumatic rotary tools, rotary vane motor is used which nothing but a rotary actuator, with the help of compressed air it provide motion to spindle. (Speed up to 25000 rpm)

Construction :

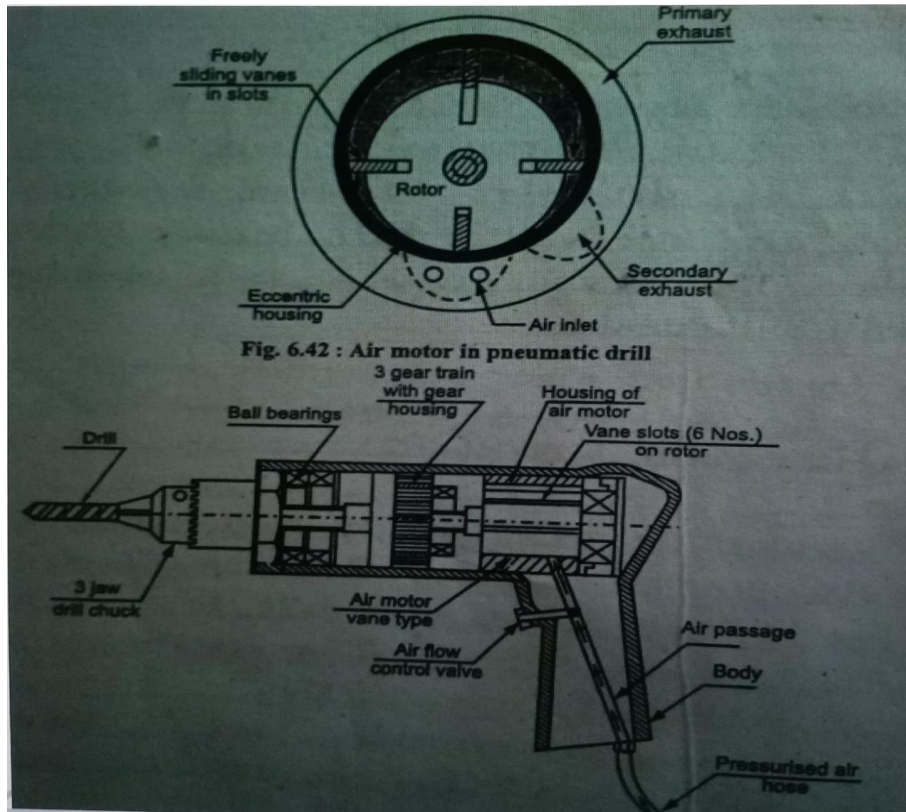

In fig shows Pneumatic drill. It is having cast iron body in which air motor (vane type) is used. The motor shaft is attached to 3 gear train and gear housing, this arrangement is similar to epicyclic gear train used in automobiles. Drill chuck is attached to spindle of gear train which transfer power developed by air to drill. There is a air supply pipe and flow of air is controlled by air flow control valves.

• Working :

When flow control valves similar to trigger of pistol is pressed the pressurized air will pass over the vanes of air motor, as shown by arrows near each vane and rotor will rotate in clockwise direction. This rotary motion will transfer to 3 gear train and thus drill will rotate.

CHAPTER 4. INTERNAL COMBUSTION ENGINES

OTTO CYCLE:

The air- standard otto cycle is the idealized cycle for spark ignition internal combustion engine.

P-V and T-S diagram of OTTO cycle

The otto cycle 1-2-3-4 consists of following processes:

- Process 1-2: Reversible adiabatic compression of air
- Process 2-3: Heat addition at constant volume.
- Process 3-4: Reversible adiabatic expansion of air.
- Process 4-1: Heat rejection at constant volume.

Process 1-2: isentropic compression of the working fluid occurs as the piston moves from bottom dead center (BDC) to top dead center (TDC).

Process 2-3: here, with the SI, a rapid burning occurs inside the piston; therefore, the heat addition takes place at the constant volume.

Process 3-4: in this process, the working fluid expands isentropically and produces the useful work for the cycle.

Process 4-1: heat removal at constant volume. In practical applications, the heat is removed by expelling the exhaust gas to the atmosphere.

Thermal efficiency

Since the processes 1-2 and 3-4 are adiabatic, no heat transfer takes place during these processes. The heat transfer is limited to addition of heat during the constant volume process and rejection of heat during constant volume process 4-1.

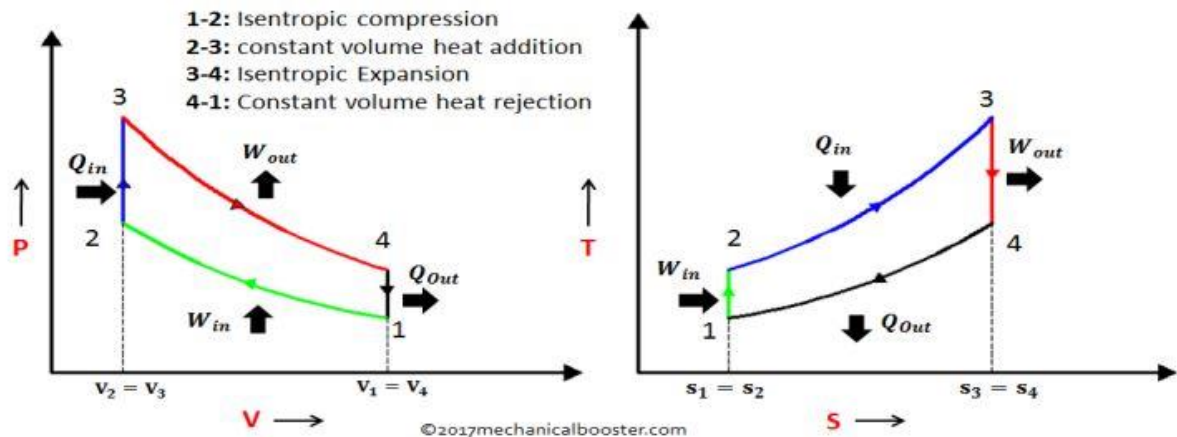

P-V and T-S Diagram of Otto Cycle

Consider 1 kg of air

$$\text{Heat added during process 2-3} = c_v(T_3 - T_2)$$

$$\text{Heat rejected during process 4-1} = c_v(T_4 - T_1)$$

$$\text{Therefore, Work done} = \text{Heat added} - \text{Heat rejected} = c_v(T_3 - T_2) - c_v(T_4 - T_1)$$

$$\text{Thermal efficiency, } \eta = \text{Wok done/Heat supplied, } \eta = \frac{c_v(T_3 - T_2) - c_v(T_4 - T_1)}{c_v(T_3 - T_2)} = \eta = 1 - \frac{(T_4 - T_1)}{(T_3 - T_2)}$$

Now compression ratio $V_1/V_2 =$ expansion ratio $V_4/V_3 = r$

Also, $r = (\text{Swept volume} + \text{clearance volume})/\text{clearance volume}$

For ideal gas $pv = RT$ and $pv^\gamma = \text{constant}$

Considering isentropic processes 1-2 and 3-4, we have

$$\frac{T_2}{T_1} = \left(\frac{V_1}{V_2}\right)^{\gamma-1} \quad \text{and} \quad \frac{T_3}{T_4} = \left(\frac{V_4}{V_3}\right)^{\gamma-1} = r^{\gamma-1}, \text{ So } T_2 = T_1 r^{\gamma-1} \text{ and } T_3 = T_4 r^{\gamma-1}$$

Hence, substituting

$$\eta = 1 - \frac{T_4 - T_1}{T_4 r^{\gamma-1} - T_1 r^{\gamma-1}} = 1 - \frac{T_4 - T_1}{(T_4 - T_1) r^{\gamma-1}} = 1 - \frac{1}{r^{\gamma-1}}$$

PROBLEM.

In an Otto cycle, the temperature at the beginning and end of the isentropic compression are 316 K and 596 K respectively. Determine the air standard efficiency and the compression ratio. Take $\gamma = 1.4$.

PROBLEM

An engine, working on the Otto cycle, has a cylinder diameter of 150 mm and a stroke of 225 mm. The clearance volume is $1.25 \times 10^{-3} \text{ m}^3$. Find the air standard efficiency of this engine. Take $\gamma = 1.4$.

DIESEL CYCLE

The air standard diesel cycle is idealized for compressed ignition internal combustion engines.

The diesel cycle 1-2-3-4 consists of the following processes

Process 1-2: Isentropic compression (Reversible adiabatic compression).

Process 2-3: Constant pressure heat addition.

Process 3-4: Isentropic expansion (Reversible adiabatic expansion).

Process 4-1: Constant volume heat rejection.

Process 1-2: isentropic compression of the working fluid occurs as the piston moves from bottom dead center (BDC) to top dead center (TDC).

Process 2-3: here, with the CI, a rapid burning occurs inside the piston; therefore, the heat addition takes place at the constant pressure.

Process 3-4: in this process, the working fluid expands isentropically and produces the useful work for the cycle.

Process 4-1: heat removal at constant volume. In practical applications, the heat is removed by expelling the exhaust gas to the atmosphere.

Let the engine cylinder contain m kg of air at point 1. At this point let P_1 , T_1 and V_1 be the pressure, temperature and volume of the air. Following are the four stages of an ideal diesel cycle.

- 1. First stage (constant pressure heating).** The air is heated at constant pressure from initial temperature T_1 to a temperature T_2 .

Heat supplied to the air,

$$Q_{1-2} = m c_p (T_2 - T_1)$$

Since the supply of heat is cut off at point 2, therefore it is known as cut-off point.

- 2. Second stage (Reversible adiabatic or isentropic expansion).**

The air is expanded reversibly and adiabatically from temperature T_2 to a temperature T_3 and in this process no heat is absorbed or rejected by the air.

- 3. Third stage (constant volume cooling).**

The air is now cooled at constant volume from temperature T_3 to a temperature T_4 .

Heat rejected by the air,

$$Q_{3-4} = m c_v (T_3 - T_4)$$

- 4. Fourth stage (Reversible adiabatic or isentropic compression)**

The air is compressed reversibly and adiabatically from temperature T_4 to a temperature T_1 .

In this process, no heat is absorbed or rejected by the air.

Work done = Heat absorbed – Heat rejected

$$= m c_p(T_2 - T_1) - m c_v(T_3 - T_4)$$

Air standard efficiency,

$$\eta = \frac{\text{Work done}}{\text{Heat absorbed}} = \frac{m c_p(T_2 - T_1) - m c_v(T_3 - T_4)}{m c_p(T_2 - T_1)}$$

$$1 - \frac{c_v}{c_p} \left(\frac{T_3 - T_4}{T_2 - T_1} \right) = 1 - \frac{1}{\gamma} \left(\frac{T_3 - T_4}{T_2 - T_1} \right) \quad \dots\dots(i)$$

Now let compression ratio,

$$r = \frac{v_4}{v_1}$$

Cut-off ratio,

$$\rho = \frac{v_2}{v_1}$$

Expansion ratio,

$$r_1 = \frac{v_3}{v_2} = \frac{v_4}{v_2}$$

$$= \frac{v_4}{v_1} \times \frac{v_1}{v_2} = r \times \frac{1}{\rho}$$

We know for constant pressure heating process 1-2,

$$\frac{v_1}{T_1} = \frac{v_2}{T_2}$$

$$T_2 = T_1 \times \frac{v_2}{v_1} = T_1 \times \rho \quad \dots\dots\dots(ii)$$

Similarly, for reversible adiabatic or isentropic expansion process 2-3,

$$\frac{T_3}{T_2} = \left(\frac{v_2}{v_3} \right)^{\gamma-1} = \left(\frac{1}{r} \right)^{\gamma-1} = \left(\frac{\rho}{r} \right)^{\gamma-1}$$

$$T_3 = T_2 \left(\frac{\rho}{r} \right)^{\gamma-1} = T_1 \times \rho \left(\frac{\rho}{r} \right)^{\gamma-1} \quad \dots\dots\dots(iii)$$

and for reversible adiabatic or isentropic expansion process 4-1,

$$\frac{T_1}{T_4} = \left(\frac{v_4}{v_1} \right)^{\gamma-1} = (r)^{\gamma-1} \quad \text{or} \quad T_1 = T_4 (r)^{\gamma-1} \quad \dots\dots\dots(iv)$$

Substituting the value of T_1 in equation (ii) and (iii),

$$T_2 = T_4 (r)^{\gamma-1} \times \rho \quad \dots\dots\dots(v)$$

$$T_3 = T_4 (r)^{\gamma-1} \times \rho \left(\frac{\rho}{r}\right)^{\gamma-1} = T_4 \rho^\gamma \dots\dots\dots(vi)$$

Now substituting the values of T_1 , T_2 and T_3 in equation (i), we get

$$\eta = 1 - \frac{1}{\gamma} \left(\frac{T_3 - T_4}{T_2 - T_1} \right) = 1 - \frac{1}{\gamma} \left[\frac{(T_4 \rho^\gamma) - T_4}{T_4 (r)^{\gamma-1} \times \rho - T_4 (r)^{\gamma-1}} \right]$$

$$= 1 - \frac{1}{r^{\gamma-1}} \left[\frac{\rho^\gamma - 1}{\gamma(\rho - 1)} \right] \quad \dots\dots\dots(vii)$$

PROBLEM

In a diesel engine, the compression ratio is 13:1 and the fuel is cut-off at 8% of the stroke. Find the air standard efficiency of the engine . Take γ for air as 1.4.

PROBLEM

In an ideal diesel cycle, the temperatures at the beginning and end of compression are 57° C and 603°C respectively. The temperatures at the beginning and end of expansion are 1950°C and 870°C respectively. Determine the ideal efficiency of the cycle . Take $\gamma = 1.4$.

If the compression ratio is 14 and the pressure at the beginning of the compression is 1 bar. Calculate the maximum pressure in the cycle.

Working of 2- stroke petrol engine

A two-stroke engine is a type of internal combustion engine. It completes a power cycle with two strokes of the piston during only one crankshaft revolution.

Construction of Two-Stroke petrol Engine

The construction of a two-stroke engine involves:

- 1.Piston:** The expanding forces of gases are transferred to the mechanical rotation of the crankshaft via a connecting rod, by the piston.
- Crankshaft:** This part allowed the conversion of reciprocating motion to rotational motion.

Connecting rod: This allows the motion of a piston to be transferred to the crankshaft.

Flywheel: A mechanical device used to store energy.

Spark Plug: Allows the expansion of gases by delivering electric current to the combustion chamber and igniting the air-fuel mixture.

Counter Weight: This part is used to reduce the vibrations due to imbalances in the rotating assembly.

Inlets and Outlets: Allows the enter and exit of fresh air into the cylinder.

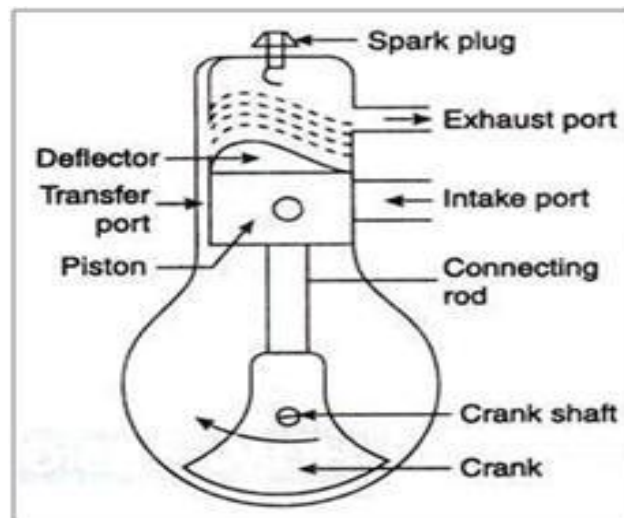

Working of Two-Stroke petrol engine Engine

The two-stroke engine cycle primarily is of two halves, up-stroke, and down-stroke. In the up-stroke, the piston is pushed from Bottom Dead Center (BDC) to the Top Dead Center (TDC). In this stroke two process occurs simultaneously one is the fuel-air mixture to be compressed and opening of the inlet port, letting the mixture get sucked inside the crankcase. During the compression spark plug ignites the mixture. This mixture then expands thus pushing the piston from TDC to BDC and there is the occurrence of down-stroke. In this stroke, two process also occurs, one is opening of exhaust port and another is the air fuel mixture goes into the combustion chamber through the transfer port from the crankcase as a partial vacuum created inside the combustion chamber. During the opening of exhaust port, the burnt gases get out from the combustion chamber. It is observed that in this stroke, the crankshaft makes a rotation of 180°.

Working of 2 stroke diesel engine

The construction of two stroke diesel engine is same as 2- stroke petrol engine, but the only difference is that, here fuel injector is used instead of spark plug.

2-Stroke Diesel (CI) Engine

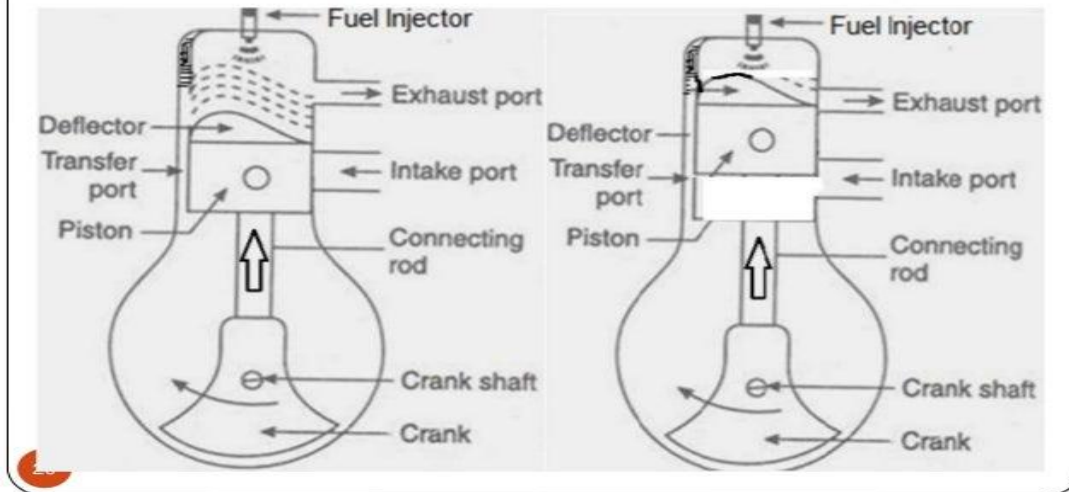

Working of 2 stroke diesel engine:

1. 1st Stroke – As the piston starts rising from its B.D.C. position, it closes the transfer and the exhaust port. The air which is already there in the cylinder is compressed. At the same time with the upward movement of the piston, vacuum is created in the crank case. As soon as the inlet port is uncovered the fresh air is sucked in the crank case. The charging is continued until the crank case and the space in the cylinder beneath the piston is filled with the air.

2. 2nd Stroke – Slightly before the completion of the compression stroke a very fine spray of diesel is injected into the compressed air (which is at a very high temperature). The fuel ignites spontaneously.

Pressure is exerted on the crown of the piston due to the combustion of the air and the piston is pushed in the downward direction producing some useful power. The downward movement of the piston will first close the inlet port and then it will compress the air already sucked in the crank case.

Just at the end of power stroke, the piston uncovers the exhaust port and the transfer port simultaneously. The expanded gases start escaping through the exhaust port and at the same time the fresh air which is already compressed in the crank case, rushes into the cylinder through the transfer port and thus the cycle is repeated again.

4-stroke petrol engine

1) Inlet valve :- From Intake Manifold Air-fuel mixture enters into the Cylinder through Inlet Valve.

2) Exhaust valve :- Burnt gases from Cylinder are Released to Exhaust Pipe through Exhaust Valve.

3) Spark Plug:- Spark Plug is connected to Cylinder. Spark Plug Produces Spark in Cylinder. Spark helps in starts burning of fuel.

4) Cylinder:- Piston Slides inside the cylinder. The cylinder head consists of an inlet port, Exhaust port, Piston & spark plug.

5) Piston:- Piston slides inside the cylinder. Piston suck (Pull) the air-fuel mixture from the intake manifold & compresses it inside the cylinder.

6) Connecting Rod:- Connecting Rod connects the piston to the crank.

One end of the connecting rod is connected to the piston. The other end of the connecting rod is connected to the crank.

7) Crank:- It Connects the connecting rod to the crankshaft. One end of the crank is connected to the connecting rod. The other end of the crank is connected to the crankshaft.

Working of 4- stroke petrol engine

1) Suction Stroke :- In Suction Stroke, Piston moves from TDC to BDC. During this stroke, Inlet valve is open, hence when Piston moves from TDC to BDC, it suck (Pull) the air-fuel mixture from the Intake Manifold. Inlet valve closes at the end of suction stroke.

2) Compression Stroke :- In compression stroke, piston compresses the air-fuel mixture to high pressure inside the cylinder. During the compression stroke piston moves from the BDC towards TDC. Both valves (Inlet and Exhaust) are the closed during a Compression Stroke. At the end of compression stroke, spark plug produces the spark to burn the fuel.

3) Power Stroke / Expansion Stroke :- It is a stroke, in which power is obtain from engine by burning the fuel. It is also called as Expansion Stroke, because due to burning of fuel, High pressure gases expands inside the cylinder and forces piston to downwards. During power stroke piston moves from the TDC towards BDC. At the end of power stroke, Exhaust port opens.

4) Exhaust Stroke :- In Exhaust stroke, piston moves from BDC to TDC. During this stroke, burn gases are releases to Exhaust Pipe through exhaust port. Exhaust valve closes, When exhaust stroke completed.

4 stroke diesel engine

Construction:

1) Inlet valve :- From Intake Manifold only fresh atmospheric Air enters into the Cylinder through Inlet Valve.

2) Exhaust valve :- Burnt gases from Cylinder are Released to Exhaust Pipe through Exhaust Valve.

3) Fuel injector: Through the fuel injector fuel is inject at the compression stroke in to the combustion chamber. Where high temp. and pressure air helps to burn the fuel.

4) Cylinder:- Piston Slides inside the cylinder. The cylinder head consists of an inlet port, Exhaust port, Piston & spark plug.

5) Piston:- Piston slides inside the cylinder. Piston suck (Pull) the air-fuel mixture from the intake manifold & compresses it inside the cylinder.

6) Connecting Rod:- Connecting Rod connects the piston to the crank.

One end of the connecting rod is connected to the piston. The other end of the connecting rod is connected to the crank.

7) Crank:- It Connects the connecting rod to the crankshaft. One end of the crank is connected to the connecting rod. The other end of the crank is connected to the crankshaft.

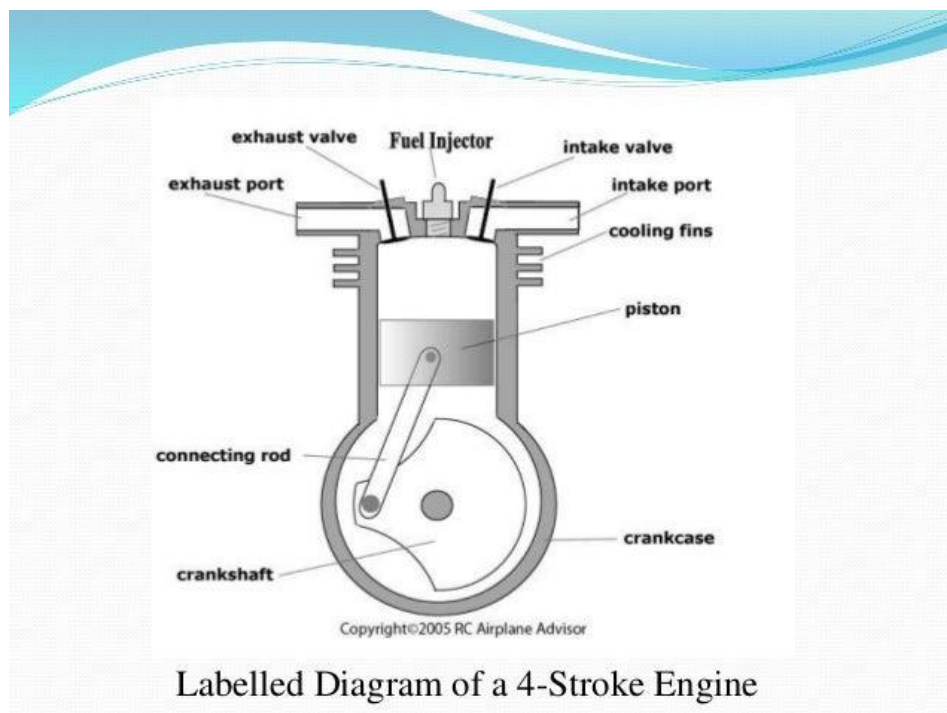

Working of four stroke diesel engine

1) Suction Stroke :- In Suction Stroke, Piston moves from TDC to BDC. During this stroke, Inlet valve is open, hence when Piston moves from TDC to BDC, it suck (Pull) the air from the Intake Manifold. Inlet valve closes at the end of suction stroke.

2) Compression Stroke :- In compression stroke, piston compresses the air to high pressure inside the cylinder. During the compression stroke piston moves from the BDC towards TDC. Both valves (Inlet and Exhaust) are the closed during a Compression Stroke. At the end of compression stroke, the injector spray the fuel to the compressed air and burn takes place inside the combustion chamber.

3) Power Stroke / Expansion Stroke :- It is a stroke, in which power is obtain from engine by burning the fuel. It is also called as Expansion Stroke, because due to burning of fuel, High pressure gases expands inside the cylinder and forces piston to downwards. During power stroke piston moves from the TDC towards BDC. At the end of power stroke, Exhaust port opens.

4) Exhaust Stroke :- In Exhaust stroke, piston moves from BDC to TDC. During this stroke, burn gases are releases to Exhaust Pipe through exhaust port. Exhaust valve closes, When exhaust stroke completed.

Indicated power :

The indicated power (I.P) is the power actually developed by the engine cylinder .

Mathematically,

$$I.P = \frac{100 K P_m L A n}{60} \text{ KW}$$

Where, K = Number of cylinders,

P_m = Actual mean effective pressure in bar, (1 bar = 100 KN/m²)

L = Length of stroke in meters,

A = Area of the piston in m²,

n = Number of working strokes per minute.

= Speed of the engine for two stroke cycle engine

= Half of the speed of the engine for four stroke cycle engine.

It can be measured by Morse test.

Brake power (B.P)

The brake power is the power available at the crank shaft. The brake power of an I.C engine ,is usually measured by means of a break mechanism.

Mathematically,

$$B P = \frac{\text{Torque in N-m} \times \text{Angle turned in radians through 1 revolution}}{60} \text{ in watts}$$

$$B.P = \frac{T \times 2 \pi N}{60} W$$

$$T = W \times l$$

Where w = Break load in newtons.

l = length of arm in meter

N = Speed of the engine in R.P.M

Mechanical efficiency

It is the ratio of break power to the indicated power .

Mathematically,

$$\eta_m = \frac{B.P}{I.P} \times 100$$

Since B.P is always less then I.P so the value of mechanical efficiency is always less than 100%.

Various applications of I.C engines in mining field

- Earth movers.
- Power shovels.
- Portable electric generators.
- Trucks
- Locomotives
- Power hammers

GPLAIPUR